

05-8FBM/05-9FBM(K)/9FBH MODELS

80V ELECTRIC PNEUMATIC



4000 - 17500 LBS.

SPECIFICATIONS



05-9FBM(H)(K)20-35T
05-8FBM40T-50T | 9FBM60-80T

CLASS

1

ELECTRIC MOTOR RIDERS

ToyotaForklift.com

80V ELECTRIC PNEUMATIC

CAPACITY
4000 - 17500 LBS.

LOAD CENTER
24 IN.

WHEELBASE
62-80 IN.

INDUSTRIES



Agriculture



Brick, Block
& Pipe



Concrete



Distribution



Oil & Gas

STANDARD FEATURES

SUPPORT

- System of Active Stability™ (SAS)
 - Active control rear stabilizer
 - Active mast function controller
- Operator presence sensing system (OPSS)
- Manual return to neutral
- Wet disc brake system
- Key lowering interlock
- Toyota Operator Restraint System (ORS)
- Overhead guard protector
- All metal, rugged exterior¹

PERFORMANCE

- AC drive system
- AC hydraulic lift system
- Maximum speed limiter
- Diagnostic code display
- Power select functions (S.P.H.)
- 3-way hydraulic control valve²
- 4-way valve³
- Accel-off function
- Three forms of energy regeneration
 - Coast control
 - Plug braking
 - Foot braking
- LCD digital multifunction display
 - Time & date
- Speedometer
- Multifunction hour meter
- Battery capacity indicator
- Over discharge warning (lift interrupt)
- Parking brake indicator
- Low speed setting switch
- Direction indicator

BODY/EXTERIOR DESIGN

- Wide view 2-stage mast (V)
- Punched plate entry/exit step
- 48" load backrest extension
- Treaded solid pneumatic tires
- Wide view carriage bars
- ORS vinyl full-suspension seat
- Retractable non-cinching seat belt
- Wide-opening battery hood⁴
- Lateral battery exchange⁵
- Bolt-on overhead guard
- Floating driver compartment⁵
- Shockless landing lift⁵
- Drive unit protector¹

OPERABILITY & ERGONOMICS

- Full hydraulic power steering²
- Electric power steering (EPS)³
- Large operator assist grip²
- Dual assist grips³
- SAS automatic fork leveling control
- Electric directional shift control
- 11.8" diameter two-spoke steering wheel
- Seat-mounted mini-lever hydraulic controls
- Heavy-duty non-slip floor mat
- Various storage compartments
- Automatic parking brake
- Wide brake pedal
- Adjustable tilt steering column
- Direction switch on armrest
- Strategically configured instrument display
- Wide foot space from accelerator pedal to hood
- Steering knob
- Synchronized steering

SERVICEABILITY

- Easy access no-tools floorboard
- Planned maintenance indicator
- Easy access controllers
- CAN-Bus controller wiring
- Battery compartment hood assist⁴
- Fanless controller cooling system³

¹ Only available on 05-8FBM40-50T, 9FBM60-80T, 9FBH80T models

² Only available on 05-9FBMK20T, 05-9FBM(K)25T, 05-9FBH25T, 05-9FBM(K)30T, 05-9FBH30T, 05-9FBM35T, 05-9FBM40-50T models

³ Only available on 9FBM60-80T, 9FBH80T models

⁴ Only available on 05-8FBM40-50T models

⁵ Only available on 05-9FBM(K)20T, 05-9FBM(K)25T, 05-9FBH25T, 05-9FBM(K)30T, 05-9FBH30T, 05-9FBM35T, 9FBM60-80T, 9FBH80T models

OPTIONAL EQUIPMENT

LOAD HANDLING

- Wide visible mast (V)
- Full-free lift two-stage mast (FV)
- Full-free lift two-cylinder two-stage mast (FW)
- Full-free lift three-stage mast (FSV)
- Full-free lift four-cylinder three-stage mast (FSW)
- Fully oil charged lift cylinders
- Shockless landing lift
- Tilt cylinder boots
- Fork bar (wide carriage)
- Less forks
- Load backrest
- Less backrest
- Long forkbar
- Hydraulic accumulator
- Clamp release interlock

LOAD HANDLING (HOSE & VALVE ASSEMBLY)

- Various valve and hosing options
- Various sideshift attachments
- Hydraulic cushioned forks
- Hydraulic accumulator
- Various quick disconnect options

LIGHTS & INDICATORS

- Various LED front and rear light options
- Various spot light options
- Various strobe light options
- Deluxe multifunction display (includes mast tilt indicator and load indicator)
- Back-up buzzer
- Operator compartment light
- Reading light
- Touchscreen and color display
- Armrest horn

BODY

- Left hand shift lever
- Seat mounted multifunction levers
- Multifunction joystick
- Speed and acceleration control (with load)
- D2 EZ pedal (2 pedals)
- Various rear view mirror options
- Drive unit protector
- Touch pad keyless entry system
- Rear assist grip with horn button
- Impact sensor
- Auto height select
- PC power supply options
- Battery low lift-out with side covers
- Battery slide-out with side covers
- Battery side extraction with fork pockets and side covers
- ORS cloth (3-way) full-suspension seat
- Swivel seat
- Orange seat belt
- Seatbelt interlock
- Raised overhead guard
- Various overhead guard screens
- Various cabin and wiper options
- Sunshade
- Sunvisor
- Retractable sun flap (windshield and roof)
- 12V power supply (automotive style)
- Telescopic steering column
- Document box
- Writing table
- Fully adjustable armrest
- Comfort set (includes cup holder, coat hanger, Z12V, and ashtray)
- Clipboard
- Hydraulic oil cooler
- E-Bar

WHEELS & TIRES

- Various tire options
- Anti-static strap
- Front and rear mudguards

SPECIAL MODEL

- Rust Proof Specification
- Weather Protection Package
- Cold Storage

OTHER

- Fan
- Battery stands
- Rear view camera
- Special paint color(s)

Not all options are available together or available on all models
Please contact your local, authorized Toyota Dealer for a complete list of available options



TRUCK SPECIFICATIONS

MODEL NUMBERS

GENERAL DATA			05-9FBMK20T	05-9FBMK25T	05-9FBM25T	05-9FBH25T	
Load Capacity	lb (kg)		4000 (1810)	5000 (2200)	5000 (2500)	5500 (2500)	
Load Center	in (mm)		24 (600)	24 (600)	24 (600)	24 (600)	
Power Type			Battery	Battery	Battery	Battery	
	Voltage	V	80	80	80	80	
Operator Position			Seated Rider	Rider Seated	Rider Seated	Rider Seated	
Tire Type	Front / Rear		Solid Pneumatic	Solid Pneumatic	Solid Pneumatic	Solid Pneumatic	
Wheels (x = driven)	Front / Rear		2x/2	2x/2	2x/2	2x/2	
EXTERIOR DIMENSIONS			05-9FBMK20T	05-9FBMK25T	05-9FBM25T	05-9FBH25T	
A	Maximum Fork Height (MFH, V mast, top of forks)	in (mm)	131.5 (3340)	131.5 (3340)	131.5 (3340)	131.5 (3340)	
B	Free-Lift (top of forks)	in (mm)	4.73 (120)	4.73 (120)	4.73 (120)	4.90 (125)	
C	Fork Size (T x W x L)	in (mm)	1.6 x 5 x 42 (40 x 125 x 1070)	1.6 x 5 x 42 (40 x 125 x 1070)	1.6 x 5 x 42 (40 x 125 x 1070)	1.8 x 5 x 42 (45 x 125 x 1070)	
D	Tilt Range (forward / backward)	deg	4.25/8.0	4.25/8	4.25/8	4.25/8	
E	Length to Fork Face	in (mm)	89.8 (2280)	89.8 (2280)	96.1 (2440)	96.6 (2453)	
F	Overall Width	in (mm)	47 (1195)	47 (1195)	47 (1195)	47 (1195)	
G	Max Lowered Height	in (mm)	88 (2235)	88 (2235)	88 (2235)	92.7 (2355)	
H	Mast Extended Height (top of load backrest)	in (mm)	156.7 (3979)	156.7 (3979)	156.7 (3979)	155.5 (3950)	
I	Overhead Guard Height	in (mm)	87.2 (2215)	87.2 (2215)	87.2 (2215)	87.2 (2215)	
J	Turning Radius (outside)	in (mm)	79.7 (2025)	79.7 (2025)	85.6 (2175)	85.6 (2175)	
K	Load Distance ¹	in (mm)	16.5 (420)	16.5 (420)	16.5 (420)	17.0 (433)	
	Basic Right-Angle Stacking Aisle Width	in (mm)	104.1 (2645)	104.1 (2645)	110 (2795)	110.6 (2808)	
PERFORMANCE DATA			05-9FBMK20T	05-9FBMK25T	05-9FBM25T	05-9FBH25T	
Speeds	Maximum Travel (forward / reverse)	Full Load	mph (km/h)	11.8 (19)	11.8 (19)	11.8 (19)	11.8 (19)
		No Load	mph (km/h)	12.4 (20)	12.4 (20)	12.4 (20)	12.4 (20)
	Lifting	Full Load	fpm (mm/sec)	90.5 (460)	90.6 (460)	90.6 (460)	78.7 (400)
		No Load	fpm (mm/sec)	124 (630)	124 (630)	124 (630)	108.3 (550)
	Lowering	Full Load	fpm (mm/sec)	110.2 (560)	110.2 (560)	110.2 (560)	110.2 (560)
		No Load	fpm (mm/sec)	88.6 (450)	88.6 (450)	88.6 (450)	88.6 (450)
Drawbar Pull	5-Minute Ratings	lbf (N)	4500 (20000)	4496 (20000)	4496 (20000)	4496 (20000)	
	60-Minute Ratings	lbf (N)	2250 (10000)	2248 (10000)	2248 (10000)	2248 (10000)	
Gradeability*	5-Minute Ratings	%	31 / 29	25 / 29	25 / 29	25 / 29	
	30-Minute Ratings	%	23 / 29	20 / 29	19 / 29	18 / 29	
TRUCK WEIGHTS			05-9FBMK20T	05-9FBMK25T	05-9FBM25T	05-9FBH25T	
Total Weight Without Battery		lb (kg)	6852 (3108)	7005 (3178)	7108 (3224)	7582 (3439)	
Weight Distribution (with standard battery)	Full Load	Front	lb (kg)	11673 (5295)	13235 (6235)	13885 (6298)	14784 (6706)
		Rear	lb (kg)	2256 (1024)	2207 (1001)	2844 (1290)	2416 (1096)
	No Load	Front	lb (kg)	4687 (2126)	5016 (2275)	5500 (2472)	5990 (2717)
		Rear	lb (kg)	4833 (2192)	5428 (2462)	5765 (2615)	5699 (2585)
TIRES			05-9FBMK20T	05-9FBMK25T	05-9FBM25T	05-9FBH25T	
Tires	Number (front / rear)		2 / 2	2 / 2	2 / 2	2 / 2	
	Size	Front	23 x 9 - 10	23 x 9 - 10	23 x 9 - 10	23 x 10 - 12	
		Rear	18 x 7 - 8	18 x 7 - 8	18 x 7 - 8	18 x 7 - 8	
Wheelbase		in (mm)	62 (1575)	62 (1575)	68.3 (1735)	68.3 (1735)	
Tread	Front	in (mm)	38.8 (986)	38.8 (986)	38.8 (986)	37.2 (946)	
	Rear	in (mm)	37 (940)	37 (940)	37 (940)	37 (940)	
Underclearance (full load)	Minimum (mast)	in (mm)	3.7 (95)	3.7 (95)	3.7 (95)	3.7 (95)	
	Center of Wheelbase	in (mm)	5.2 (132)	5.2 (132)	5.2 (132)	5.2 (132)	
Brake	Service (foot)		Mechanical/hydraulic	Mechanical/Hydraulic	Mechanical/Hydraulic	Mechanical/Hydraulic	
	Parking (auto)		Electro-mechanical	Electro-mechanical	Electro-mechanical	Electro-mechanical	
POWER SYSTEM			05-9FBMK20T	05-9FBMK25T	05-9FBM25T	05-9FBH25T	
Battery	(5-hour ratings)	V/Ah	80 / 500	80 / 560	80 / 700	80 / 700	
Electric Motors	Drive	hp (kW)	28.8 (21.4)	28.8 (21.4)	28.8 (21.4)	28.8 (21.4)	
	Load Handling	hp (kW)	22.5 (16.7)	22.5 (16.7)	22.5 (16.7)	22.5 (16.7)	
Control Type	Drive, Load Handling, Power Steering		Inverter Mosfet	Inverter Mosfet	Inverter Mosfet	Inverter Mosfet	
Auxiliary Hydraulic Function Specifications (for attachments) ²	Max. Operating Pressure	psi (bar)	2321 (160)	2321 (160)	2321 (160)	2321 (160)	
	Maximum Flow Rate	gpm (lmp)	10.6 (40)	10.6 (40)	10.6 (40)	10.6 (40)	

* Computed values.
 1 Values indicated reflect speeds in H mode
 2 Values taken at Hydraulic Control Valve. Does not take into consideration losses through mast plumbing (hosing, fittings, QDs, etc.)

TRUCK SPECIFICATIONS

MODEL NUMBERS

GENERAL DATA			05-9FBMK30T	05-9FBM30T	05-9FBH30T	05-9FBM35T	
Load Capacity		lb (kg)	6000 (2710)	6000 (3000)	6500 (3000)	7000 (3500)	
Load Center		in (mm)	24 (600)	24 (600)	24 (600)	24 (600)	
Power Type			Battery	Battery	Battery	Battery	
	Voltage	V	80	80	80	80	
Operator Position			Rider Seated	Rider Seated	Rider Seated	Rider Seated	
Tire Type	Front / Rear		Solid Pneumatic	Solid Pneumatic	Solid Pneumatic	Solid Pneumatic	
Wheels (x = driven)	Front / Rear		2x/2	2x/2	2x/2	2x/2	
EXTERIOR DIMENSIONS			05-9FBMK30T	05-9FBM30T	05-9FBH30T	05-9FBM35T	
A Maximum Fork Height (MFH, V mast, top of forks)		in (mm)	131.5 (3340)	131.5 (3340)	131.5 (3340)	131.5 (3340)	
B Free-Lift (top of forks)		in (mm)	4.90 (125)	4.90 (125)	4.90 (125)	4.9 (125)	
C Fork Size (T x W x L)		in (mm)	1.8 x 5 x 42 (45 x 125 x 1070)	1.8 x 5 x 42 (45 x 125 x 1070)	1.8 x 5 x 42 (45 x 125 x 1070)	2 x 6 x 42 (50 x 150 x 1070)	
D Tilt Range (forward / backward)		deg	4.25/8	4.25/8	4.25/8	4.25/8	
E Length to Fork Face		in (mm)	91.7 (2328)	96.9 (2460)	97.7 (2481)	98.0 (2488)	
F Overall Width		in (mm)	47 (1195)	47 (1195)	47 (1195)	51.1 (1299)	
G Mast Lowered Height		in (mm)	94.3 (2395)	94.3 (2395)	92.7 (2355)	94.3 (2395)	
H Mast Extended Height (top of load backrest)		in (mm)	158.9 (4035)	158.9 (4035)	155.5 (3950)	158.9 (4035)	
I Overhead Guard Height		in (mm)	87.2 (2215)	87.2 (2215)	87.2 (2215)	87.2 (2215)	
J Turning Radius (outside)		in (mm)	80.2 (2038)	85.6 (2175)	86.6 (2200)	86.6 (2200)	
K Load Distance ¹		in (mm)	17.3 (440)	17.3 (440)	17.0 (433)	17.3 (440)	
Basic Right-Angle Stacking Aisle Width		in (mm)	105.4 (2678)	110.8 (2815)	111.5 (2833)	111.8 (2840)	
PERFORMANCE DATA			05-9FBMK30T	05-9FBM30T	05-9FBH30T	05-9FBM35T	
Speeds	Maximum Travel (forward / reverse)	Full Load	mph (km/h)	11.8 (19)	11.8 (19)	11.8 (19)	11.8 (19)
		No Load	mph (km/h)	12.4 (20)	12.4 (20)	12.4 (20)	12.4 (20)
	Lifting	Full Load	fpm (mm/sec)	78.7 (400)	78.7 (400)	78.7 (400)	72.8 (370)
		No Load	fpm (mm/sec)	108.2 (550)	108.2 (550)	108.3 (550)	108.3 (550)
	Lowering	Full Load	fpm (mm/sec)	110.2 (560)	110.2 (560)	110.2 (560)	110.2 (560)
		No Load	fpm (mm/sec)	88.6 (450)	88.6 (450)	88.6 (450)	88.6 (450)
Drawbar Pull	5-Minute Ratings	lbf (N)	4496 (20000)	4496 (20000)	4496 (20000)	4496 (20000)	
	60-Minute Ratings	lbf (N)	2248 (10000)	2248 (10000)	2248 (10000)	2248 (10000)	
Gradeability*	5-Minute Ratings	%	23 / 29	23 / 29	23 / 29	20 / 29	
	30-Minute Ratings	%	17 / 29	17 / 29	16 / 27	15 / 26	
TRUCK WEIGHTS			05-9FBMK30T	05-9FBM30T	05-9FBH30T	05-9FBM35T	
Total Weight Without Battery		lb (kg)	8327 (3777)	7721 (3502)	8351 (3788)	8505 (3858)	
Weight Distribution (with standard battery)	Full Load	Front	lb (kg)	16065 (7287)	16182 (7340)	16515 (7491)	17,871 (8106)
		Rear	lb (kg)	2310 (1048)	2260 (1025)	2557 (1160)	2458 (1115)
	No Load	Front	lb (kg)	5503 (2496)	5798 (2630)	964 (2705)	5972 (2709)
		Rear	lb (kg)	6259 (2839)	5789 (2626)	6495 (2946)	6640 (3012)
TIRES			05-9FBMK30T	05-9FBM30T	05-9FBH30T	05-9FBM35T	
Tires	Number (front / rear)		2 / 2	2 / 2	2 / 2	2 / 2	
	Size	Front	23 x 10 - 12	23 x 10 - 12	23 x 10 - 12	315/45-12	
		Rear	18 x 7 - 8	18 x 7 - 8	200/50-10	200/50-10	
Wheelbase		in (mm)	62 (1575)	68.3 (1735)	68.3 (1735)	68.3 (1735)	
Tread	Front	in (mm)	37.2 (946)	37.2 (946)	37.2 (946)	39.7 (1009)	
	Rear	in (mm)	37 (940)	37 (940)	37.9 (962)	37.9 (962)	
Underclearance (full load)	Minimum (mast)	in (mm)	3.7 (95)	3.7 (95)	3.7 (95)	3.7 (95)	
	Center of Wheelbase	in (mm)	5.2 (132)	5.2 (132)	5.2 (132)	5.2 (132)	
Brake	Service (foot)		Mechanical/Hydraulic	Mechanical/Hydraulic	Mechanical/Hydraulic	Mechanical/Hydraulic	
	Parking (auto)		Electro-mechanical	Electro-mechanical	Electro-mechanical	Electro-mechanical	
POWER SYSTEM			05-9FBMK30T	05-9FBM30T	05-9FBH30T	05-9FBM35T	
Battery	(5-hour ratings)	V/Ah	80 / 560	80 / 700	80 / 700	80 / 700	
Electric Motors	Drive	hp (kW)	28.8 (21.4)	28.8 (21.4)	28.8 (21.4)	28.8 (21.4)	
	Load Handling	hp (kW)	22.5 (16.7)	22.5 (16.7)	22.5 (16.7)	22.5 (17.3)	
Control Type	Drive, Load Handling, Power Steering		Inverter Mosfet	Inverter Mosfet	Inverter Mosfet	Inverter Mosfet	
Auxiliary Hydraulic Function Specifications (for attachments) ²	Max. Operating Pressure	psi (bar)	2321 (160)	2321 (160)	2321 (160)	2321 (160)	
	Maximum Flow Rate	gpm (lmp)	10.6 (40)	10.6 (40)	10.6 (40)	10.6 (40)	

* Computed values
 1 Values indicated reflect speeds in H mode
 2 Values taken at Hydraulic Control Valve. Does not take into consideration losses through mast plumbing (hosing, fittings, QDs, etc.)

MODEL NUMBERS

GENERAL DATA				05-8FBM40T	05-8FBM45T	05-8FBM50T
Load Capacity		lb (kg)		8000 (3640)	9000 (4090)	11,000 (4990)
Load Center		in (mm)		24 (610)	24 (610)	24 (610)
Power Type				Battery	Battery	Battery
	Voltage	V		80	80	80
Operator Position				Rider Seated	Rider Seated	Rider Seated
Tire Type	Front / Rear			Solid Pneumatic	Solid Pneumatic	Solid Pneumatic
Wheels (x = driven)	Front / Rear			2x/2	2x/2	2x/2
EXTERIOR DIMENSIONS				05-8FBM40T	05-8FBM45T	05-8FBM50T
A	Maximum Fork Height (MFH, V mast, top of forks)	in (mm)		131.9 (3350)	131.9 (3350)	132.3 (3360)
B	Free-Lift (top of forks)	in (mm)		5.1 (130)	5.1 (130)	5.5 (140)
C	Fork Size (T x W x L)	in (mm)		1.8 x 5 x 42 / (45 x 125 x 1070)	1.8 x 5 x 42 / (45 x 125 x 1070)	1.8 x 5 x 42 / (45 x 125 x 1070)
D	Tilt Range (forward / backward)	deg		5/10	5/10	5/10
E	Length to Fork Face	in (mm)		114.4 (2907)	116.0 (2947)	120.9 (3072)
F	Overall Width	in (mm)		53.0 (1345)	53.0 (1345)	56.7 (1440)
G	Mast Lowered Height	in (mm)		98.4 (2500)	98.4 (2500)	98.4 (2500)
H	Mast Extended Height (top of load backrest)	in (mm)		179.9 (4570)	179.9 (4570)	180.3 (4580)
I	Overhead Guard Height	in (mm)		92.9 (2360)	92.9 (2360)	92.9 (2360)
J	Turning Radius (outside)	in (mm)		100.1 (2543)	100.7 (2558)	105.7 (2686)
K	Load Distance ¹	in (mm)		20.4 (518)	20.4 (518)	20.8 (528)
	Basic Right-Angle Stacking Aisle Width	in (mm)		120.5 (3061)	121.1 (3076)	126.5 (3214)
PERFORMANCE DATA				05-8FBM40T	05-8FBM45T	05-8FBM50T
Speeds	Maximum Travel (forward / reverse)	Full Load	mph (km/h)	11.0 (18)	11.0 (18)	11.0 (18)
		No Load	mph (km/h)	11.0 (18)	11.0 (18)	11.0 (18)
	Lifting	Full Load	fpm (mm/sec)	68.9 (350)	68.9 (350)	65.0 (330)
		No Load	fpm (mm/sec)	90.6 (460)	90.6 (460)	90.6 (460)
	Lowering	Full Load	fpm (mm/sec)	108.3 (550)	108.3 (550)	108.3 (550)
		No Load	fpm (mm/sec)	90.3 (460)	90.3 (460)	90.3 (460)
Drawbar Pull	5-Minute Ratings	lbf (N)	4946 (22,000)	4946 (22,000)	4946 (22,000)	
	60-Minute Ratings	lbf (N)	2792 (12,420)	2792 (12,420)	2792 (12,420)	
Gradeability*	5-Minute Ratings	%	15 / 25	14 / 24	13 / 23	
	30-Minute Ratings	%	11.3 / 17.0	9.5 / 16.8	8.8 / 15.8	
TRUCK WEIGHTS				05-8FBM40T	05-8FBM45T	05-8FBM50T
Total Weight Without Battery		lb (kg)		9652 (4378)	10,820 (4908)	12,220 (5543)
Weight Distribution (with standard battery)	Full Load	Front	lb (kg)	21,065 (9555)	22,622 (10,261)	24,948 (11,316)
		Rear	lb (kg)	2429 (1102)	2921 (1325)	3100 (1406)
	No Load	Front	lb (kg)	7844 (3558)	7749 (3515)	7822 (3548)
		Rear	lb (kg)	6832 (3099)	7875 (3572)	9200 (3548)
TIRES				05-8FBM40T	05-8FBM45T	05-8FBM50T
Tires	Number (front / rear)			2 / 2	2 / 2	2 / 2
	Size	Front		250 - 15	250 - 15	28 x 12.5 - 15
		Rear		23 x 9 - 10	23 x 9 - 10	23 x 9 - 10
Wheelbase		in (mm)		79.9 (2030)	79.9 (2030)	79.9 (2030)
Tread	Front	in (mm)		44.1 (1119)	44.1 (1119)	45.1 (1145)
	Rear	in (mm)		43.8 (1113)	43.8 (1113)	43.8 (1113)
Underclearance (full load)	Minimum (mast)	in (mm)		5.9 (150)	5.9 (150)	5.9 (150)
	Center of Wheelbase	in (mm)		5.7 (145)	5.7 (145)	5.7 (145)
Brake	Service (foot)			Hydraulic	Hydraulic	Hydraulic
	Parking (auto)			Electro-mechanical	Electro-mechanical	Electro-mechanical
POWER SYSTEM				05-8FBM40T	05-8FBM45T	05-8FBM50T
Battery	(5-hour ratings)	V/Ah		80 / 840	80 / 840	80 / 840
Electric Motors	Drive	hp (kW)		33.8 (25.2)	33.8 (25.2)	33.8 (25.2)
	Load Handling	hp (kW)		34.2 (25.5)	34.2 (25.5)	34.2 (25.5)
Control Type	Drive, Load Handling, Power Steering			Transistor Invertor	Transistor Invertor	Transistor Invertor
Auxiliary Hydraulic Function Specifications (for attachments) ²	Max. Operating Pressure	psi (bar)		2320 - 2610 (160 - 180) adjustable	2320 - 2610 (160 - 180) adjustable	2320 - 2610 (160 - 180) adjustable
	Maximum Flow Rate	gpm (lmp)		18.5 (70)	18.5 (70)	18.5 (70)

* Computed values

¹ Values indicated reflect speeds in H mode

² Values taken at Hydraulic Control Valve. Does not take into consideration losses through mast plumbing (hosing, fittings, QDs, etc.)

80V ELECTRIC PNEUMATIC

MODEL NUMBERS

GENERAL DATA			9FBM60T	9FBM70T	9FBM80T	9FBH80T
Load Capacity		lb (kg)	13000 (6000)	15500 (7000)	17500 (8000)	17500 (8000)
Load Center		in (mm)	24 (600)	24 (600)	24 (600)	36 (900)
Power Type			Battery	Battery	Battery	Battery
	Voltage	V	80	80	80	80
Operator Position			Driver Seated	Driver Seated	Driver Seated	Driver Seated
Tire Type	Front / Rear		Solid Pneumatic	Solid Pneumatic	Solid Pneumatic	Solid Pneumatic
Wheels (x = driven)	Front / Rear		2x/2	4x/2	4x/2	4x/2

EXTERIOR DIMENSIONS			9FBM60T	9FBM70T	9FBM80T	9FBH80T
A Maximum Fork Height (MFH, V mast, top of forks)		in (mm)	132 (3360)	132 (3360)	132 (3360)	132.5 (3370)
B Free-Lift (top of forks)		in (mm)	3.9 (100)	3.9 (100)	3.9 (100)	3.9 (100)
C Fork Size (T x W x L)		in (mm)	2.5 x 6 x 48 (65x150x1220)	2.5 x 6 x 48 (65x150x1220)	2.75 x 6 x 48 (70x150x1220)	2.75 x 6 x 72 (70x150x1820)
D Tilt Range (forward / backward)		deg	5/8	5/8	5/8	5/8
E Length to Fork Face		in (mm)	137 (3480)	137.4 (3490)	137.6 (3495)	143.7 (3650)
F Overall Width		in (mm)	65.4 (1660)	78.9 (2004)	84.3 (2141)	84.3 (2141)
G Mast Lowered Height		in (mm)	103.1 (2620)	107.1 (2720)	103.1 (2620)	111 (2820)
H Mast Extended Height (top of load backrest)		in (mm)	167.4 (4252)	171.3 (4352)	167.5 (4255)	176.4 (4480)
I Overhead Guard Height		in (mm)	111.6 (2835)	111.6 (2835)	111.6 (2835)	111.6 (2835)
J Turning Radius (outside)		in (mm)	118.3 (3005)	118.3 (3005)	118.3 (3005)	122.5 (3111)
K Load Distance ¹		in (mm)	28 (700)	28 (710)	28 (715)	30 (750)
Basic Right-Angle Stacking Aisle Width		in (mm)	146 (3705)	146.5 (3720)	152 (3861)	

PERFORMANCE DATA				9FBM60T	9FBM70T	9FBM80T	9FBH80T
Speeds	Maximum Travel (forward / reverse)	Full Load	mph (km/h)	11 (18)	11 (18)	11 (17)	10 (16)
		No Load	mph (km/h)	12 (20)	12 (20)	12 (19)	11 (18)
	Lifting	Full Load	fpm (mm/sec)	75 (380)	71 (360)	63 (320)	63 (320)
		No Load	fpm (mm/sec)	95 (480)	95 (480)	83 (420)	83 (420)
	Lowering	Full Load	fpm (mm/sec)	108 (550)	108 (550)	108 (550)	108 (550)
		No Load	fpm (mm/sec)	89 (450)	89 (450)	89 (450)	89 (450)
Drawbar Pull	5-Minute Ratings	lbf (N)	10027 (44600)	10027 (44600)	10027 (44600)	10027 (44600)	
	60-Minute Ratings	lbf (N)	3726 (16573)	3650 (16237)	3563 (15848)	3499 (15562)	
Gradeability*	5-Minute Ratings	%	19	18	16	16	
	30-Minute Ratings	%	7	6	5.6	5.2	

TRUCK WEIGHTS			9FBM60T	9FBM70T	9FBM80T	9FBH80T	
Total Weight Without Battery		lb (kg)	22002 (9980)	23570 (10691)	25741 (11676)	28953 (13133)	
Weight Distribution (with standard battery)	Full Load	Front	lb (kg)	36211 (16425)	40744 (18481)	44525 (20196)	47543 (21565)
		Rear	lb (kg)	5159 (2340)	4398 (1995)	4993 (2265)	5628 (2553)
	No Load	Front	lb (kg)	15507 (7034)	16521 (7494)	16804 (7622)	17253 (7826)
		Rear	lb (kg)	12635 (5731)	12990 (5892)	15077 (6839)	17840 (8092)

TIRES			9FBM60T	9FBM70T	9FBM80T	9FBH80T
Tires	Number (front / rear)		2 / 2	4 / 2	4 / 2	4 / 2
	Size	Front	355/50-20	8.25-15	300-15	300-15
Rear		8.25-15	8.25-15	300-15	300-15	
Wheelbase		in (mm)	90.6 (2300)	90.6 (2300)	90.6 (2300)	90.6 (2300)
Tread	Front	in (mm)	52.3 (1328)	59.4 (1510)	62 (1575)	62 (1575)
	Rear	in (mm)	55.4 (1406)	55.4 (1406)	55 (1394)	55 (1394)
Underclearance (full load)	Minimum (mast)	in (mm)	8.7 (220)	8.7 (220)	8.7 (220)	8.7 (220)
	Center of Wheelbase	in (mm)	8.3 (210)	8.3 (210)	8.3 (210)	8.3 (210)
Brake	Service (foot)		Hydraulic	Hydraulic	Hydraulic	Hydraulic
	Parking (auto)		Electro-mechanical	Electro-mechanical	Electro-mechanical	Electro-mechanical

POWER SYSTEM			9FBM60T	9FBM70T	9FBM80T	9FBH80T
Battery	(5-hour rating)	V/AH	80 / 1120	80 / 1120	80 / 1120	80 / 1120
Electric Motors	Drive	hp (kW)	2x 28.4 (21.2)	2x 28.4 (21.2)	2x 28.4 (21.2)	2x 28.4 (21.2)
	Load Handling	hp (kW)	42.9 (32)	42.9 (32)	42.9 (32)	42.9 (32)
Control Type	Drive, Load Handling, Power Steering		Inverter MOSFET	Inverter MOSFET	Inverter MOSFET	Inverter MOSFET
Auxiliary Hydraulic Function Specifications (for attachments) ²	Max. Operating Pressure	psi (bar)	3626 (250)	3626 (250)	3626 (250)	3626 (250)
	Maximum Flow Rate	gpm (lmp)	21 (80)	21 (80)	21 (80)	21 (80)

* Computed values

¹ Values indicated reflect speeds in H mode

² Values taken at Hydraulic Control Valve. Does not take into consideration losses through mast plumbing (hosing, fittings, QD's, etc)

EXTERIOR DIMENSIONS

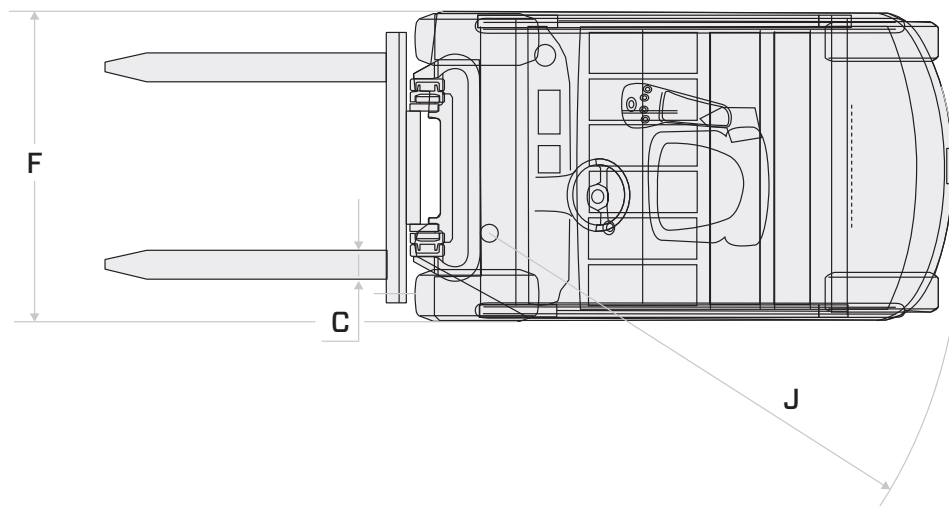
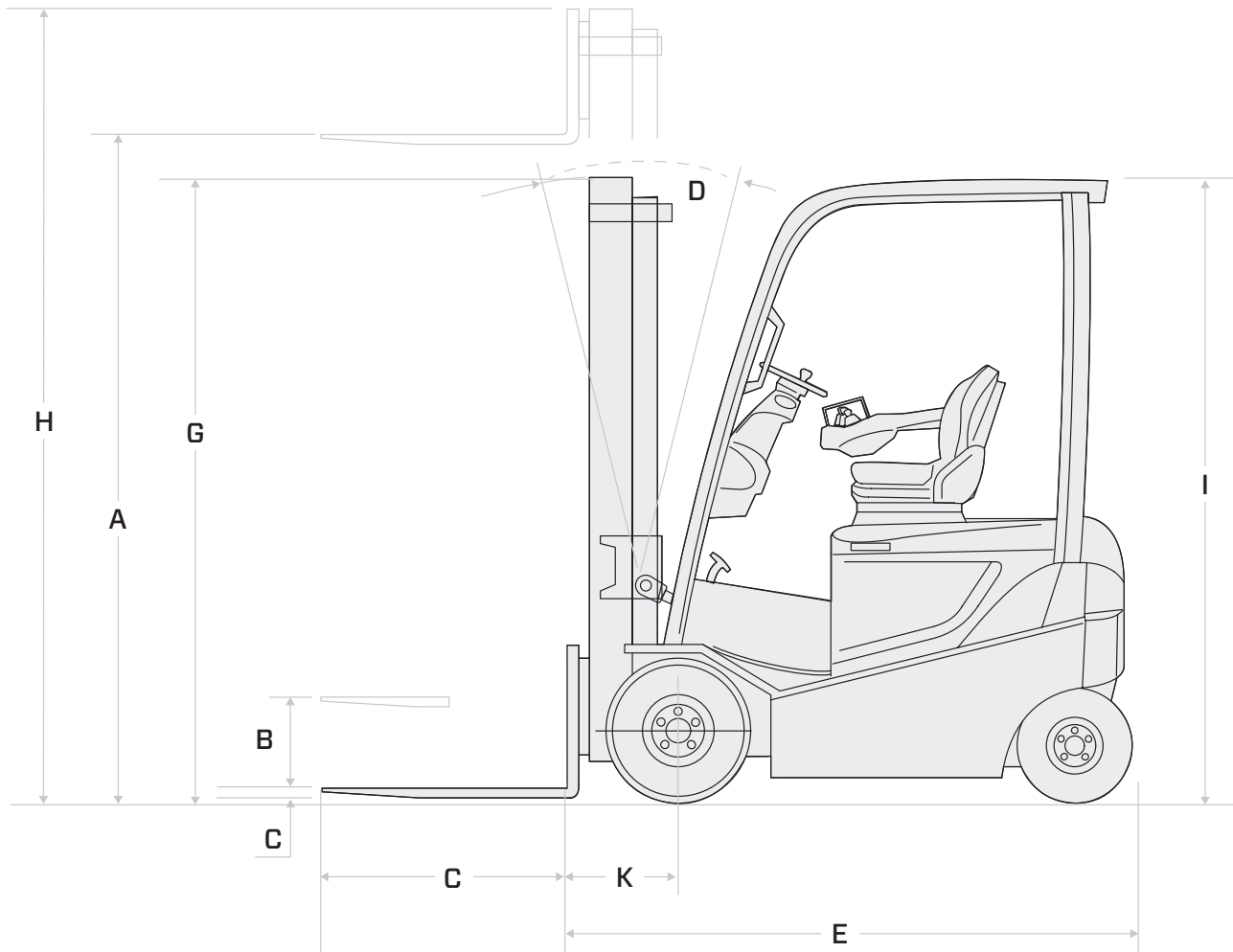



KOMET
FORLI
MATR 1705

08072351

08072351

2308



MAST SPECIFICATIONS

MAST TYPE	MAXIMUM FORK HEIGHT (TOP OF FORKS)	OVERALL HEIGHT			FREE-LIFT		TILT RANGE		LOAD CAPACITY AT
		LOWERED	EXTENDED		WITHOUT LOAD BACKREST	WITH STANDARD LOAD BACKREST ¹	FWD	BWD	24 IN. (610 MM) LOAD CENTER*
			WITHOUT LOAD BACKREST	WITH STANDARD LOAD BACKREST ¹					
	in (mm)	in (mm)	in (mm)	in (mm)	in (mm)	in (mm)	deg	deg	lb (kg)
05-9FBMK20T									
Wide Visible (V)	119.5 (3040)	84.1 (2135)	144.8 (3679)	166.1 (4220)	4.7 (120)	4.7 (120)	4.25	8	3990 (1810)
	131.5 (3340)	88 (2235)	156.7 (3979)	178 (4520)	4.7 (120)	4.7 (120)	4.25	8	3990 (1810)
	147 (3740)	101.8 (2585)	173 (4395)	193.7 (4920)	4.7 (120)	4.7 (120)	4.25	8	3990 (1810)
	159 (4040)	111.6 (2835)	188.8 (4795)	205.5 (5220)	4.7 (120)	4.7 (120)	4.25	8	3990 (1810)
	179 (4540)	121.5 (3085)	208.5 (5295)	225.2 (5720)	4.7 (120)	4.7 (120)	4.25	6	3990 (1810)
Full Free-Lift 2-Stage (FV)	119.5 (3040)	84.1 (2135)	144.6 (3674)	168.9 (4289)	59.1 (1501)	34.9 (886)	4.25	8	3990 (1810)
	131.5 (3340)	88 (2235)	156.5 (3974)	180.7 (4589)	63 (1601)	38.8 (986)	4.25	8	3990 (1810)
	147 (3740)	101.8 (2585)	172.2 (4374)	196.4 (4989)	76.8 (1951)	52.6 (1336)	4.25	8	3990 (1810)
Full Free-Lift 2-Stage, 4-Cylinder (FW)	119.5 (3040)	82.9 (2105)	141.9 (3605)	166.1 (4220)	59.1 (1500)	36.4 (925)	4.25	8	3990 (1810)
	131.5 (3340)	88 (2235)	153.7 (3905)	178 (4520)	64.2 (1630)	41.5 (1055)	4.25	8	3990 (1810)
	147 (3740)	98.6 (2505)	169.5 (4305)	193.7 (4920)	74.8 (1900)	52.2 (1325)	4.25	8	3990 (1810)
Full Free-Lift 3-Stage (FSV)	159 (4040)	104.5 (2655)	181.3 (4605)	205.5 (5220)	80.7 (2050)	58.1 (1475)	4.25	8	3990 (1810)
	171 (4340)	84.1 (2135)	195.8 (4974)	220 (5589)	57.5 (1461)	34.9 (886)	4.25	6	3990 (1810)
	186.5 (4740)	88 (2235)	211.6 (5374)	235.8 (5989)	61.5 (1561)	38.8 (986)	4.25	6	3990 (1810)
	198 (5040)	94.3 (2395)	223.4 (5674)	247.6 (6289)	67.8 (1721)	45.1 (1146)	4.25	6	3990 (1810)
	218 (5540)	101.8 (2585)	243.1 (6174)	267.3 (6789)	75.2 (1911)	52.6 (1336)	4.25	6	3880 (1760)
Full Free-Lift 3-Stage, 4-Cylinder (FSW)	238 (6040)	111.6 (2835)	262.8 (6674)	287 (7289)	85.1 (2161)	62.4 (1586)	4.25	6	3858 (1750)
	257 (6540)	121.5 (3085)	282.4 (7174)	306.7 (7789)	94.9 (2411)	72.3 (1836)	4.25	6	3660 (1660)
	173 (4390)	82.9 (2105)	195.1 (4955)	219.3 (5570)	59.1 (1500)	36.4 (925)	4.25	6	3990 (1810)
	186.5 (4740)	86.8 (2205)	208.6 (5305)	233.1 (5920)	63 (1600)	40.4 (1025)	4.25	6	3990 (1810)
	198 (5040)	90.7 (2305)	220.7 (5605)	244.9 (6220)	66.9 (1700)	44.3 (1125)	4.25	6	3990 (1810)
Full Free-Lift 3-Stage, 4-Cylinder (FSW)	218 (5540)	98.6 (2505)	240.4 (6105)	264.6 (6720)	74.8 (1900)	52.2 (1325)	4.25	6	3880 (1760)
	238 (6040)	104.5 (2655)	260.3 (6605)	284.3 (7220)	80.7 (2050)	58.1 (1475)	4.25	6	3858 (1750)
	257 (6540)	112.4 (2855)	279.7 (7105)	303.9 (7720)	88.6 (2250)	65.9 (1675)	4.25	6	3660 (1660)

MAST TYPE	MAXIMUM FORK HEIGHT (TOP OF FORKS)	OVERALL HEIGHT			FREE-LIFT		TILT RANGE		LOAD CAPACITY AT
		LOWERED	EXTENDED		WITHOUT LOAD BACKREST	WITH STANDARD LOAD BACKREST ¹	FWD	BWD	24 IN. (610 MM) LOAD CENTER*
			WITHOUT LOAD BACKREST	WITH STANDARD LOAD BACKREST ¹					
	in (mm)	in (mm)	in (mm)	in (mm)	in (mm)	in (mm)	deg	deg	lb (kg)
05-9FBMK25T									
Wide Visible (V)	119.5 (3040)	84.1 (2135)	144.8 (3679)	166.1 (4220)	4.7 (120)	4.7 (120)	4.25	8	4850 (2200)
	131.5 (3340)	88 (2235)	156.7 (3979)	178 (4520)	4.7 (120)	4.7 (120)	4.25	8	4850 (2200)
	147 (3740)	101.8 (2585)	173 (4395)	193.7 (4920)	4.7 (120)	4.7 (120)	4.25	8	4850 (2200)
	159 (4040)	111.6 (2835)	188.8 (4795)	205.5 (5220)	4.7 (120)	4.7 (120)	4.25	8	4850 (2200)
	179 (4540)	121.5 (3085)	208.5 (5295)	225.2 (5720)	4.7 (120)	4.7 (120)	4.25	6	4850 (2200)
Full Free-Lift 2-Stage (FV)	119.5 (3040)	84.1 (2135)	144.6 (3674)	168.9 (4289)	59.1 (1501)	34.9 (886)	4.25	8	4850 (2200)
	131.5 (3340)	88 (2235)	156.5 (3974)	180.7 (4589)	63 (1601)	38.8 (986)	4.25	8	4850 (2200)
	147 (3740)	101.8 (2585)	172.2 (4374)	196.4 (4989)	76.8 (1951)	52.6 (1336)	4.25	8	4850 (2200)
Full Free-Lift 2-Stage, 4-Cylinder (FW)	119.5 (3040)	82.9 (2105)	141.9 (3605)	166.1 (4220)	59.1 (1500)	36.4 (925)	4.25	8	4850 (2200)
	131.5 (3340)	88 (2235)	153.7 (3905)	178 (4520)	64.2 (1630)	41.5 (1055)	4.25	8	4850 (2200)
	147 (3740)	98.6 (2505)	169.5 (4305)	193.7 (4920)	74.8 (1900)	52.2 (1325)	4.25	8	4850 (2200)
Full Free-Lift 3-Stage (FSV)	159 (4040)	104.5 (2655)	181.3 (4605)	205.5 (5220)	80.7 (2050)	58.1 (1475)	4.25	8	4850 (2200)
	171 (4340)	84.1 (2135)	195.8 (4974)	220 (5589)	57.5 (1461)	34.9 (886)	4.25	6	4850 (2200)
	186.5 (4740)	88 (2235)	211.6 (5374)	235.8 (5989)	61.5 (1561)	38.8 (986)	4.25	6	4850 (2200)
	198 (5040)	94.3 (2395)	223.4 (5674)	247.6 (6289)	67.8 (1721)	45.1 (1146)	4.25	6	4785 (2170)
	218 (5540)	101.8 (2585)	243.1 (6174)	267.3 (6789)	75.2 (1911)	52.6 (1336)	4.25	6	4585 (2080)
Full Free-Lift 3-Stage, 4-Cylinder (FSW)	238 (6040)	111.6 (2835)	262.8 (6674)	287 (7289)	85.1 (2161)	62.4 (1586)	4.25	6	4365 (1980)
	257 (6540)	121.5 (3085)	282.4 (7174)	306.7 (7789)	94.9 (2411)	72.3 (1836)	4.25	6	3965 (1800)
	173 (4390)	82.9 (2105)	195.1 (4955)	219.3 (5570)	59.1 (1500)	36.4 (925)	4.25	6	4850 (2200)
	186.5 (4740)	86.8 (2205)	208.6 (5305)	233.1 (5920)	63 (1600)	40.4 (1025)	4.25	6	4850 (2200)
	198 (5040)	90.7 (2305)	220.7 (5605)	244.9 (6220)	66.9 (1700)	44.3 (1125)	4.25	6	4785 (2170)
Full Free-Lift 3-Stage, 4-Cylinder (FSW)	218 (5540)	98.6 (2505)	240.4 (6105)	264.6 (6720)	74.8 (1900)	52.2 (1325)	4.25	6	4585 (2080)
	238 (6040)	104.5 (2655)	260.3 (6605)	284.3 (7220)	80.7 (2050)	58.1 (1475)	4.25	6	4365 (1980)
	257 (6540)	112.4 (2855)	279.7 (7105)	303.9 (7720)	88.6 (2250)	65.9 (1675)	4.25	6	3965 (1800)

¹ Height of standard load backrest is 48" (1220 mm)
 * All capacities of 1,500 lbs or less are subject to a secondary review and could be denied by Toyota

MAST TYPE	MAXIMUM FORK HEIGHT (TOP OF FORKS)	OVERALL HEIGHT			FREE-LIFT		TILT RANGE		LOAD CAPACITY AT
		LOWERED	EXTENDED		WITHOUT LOAD BACKREST	WITH STANDARD LOAD BACKREST ¹	FWD	BWD	24 IN. (610 MM) LOAD CENTER*
			WITHOUT LOAD BACKREST	WITH STANDARD LOAD BACKREST ¹					lb (kg)
	in (mm)	in (mm)	in (mm)	in (mm)	in (mm)	in (mm)	deg	deg	lb (kg)
05-9FBM25T									
Wide Visible (V)	119.5 (3040)	84.1 (2135)	144.8 (3679)	166.1 (4220)	4.7 (120)	4.7 (120)	4.25	8	4850 (2200)
	131.5 (3340)	88 (2235)	156.7 (3979)	178 (4520)	4.7 (120)	4.7 (120)	4.25	8	4850 (2200)
	147 (3740)	101.8 (2585)	173 (4395)	193.7 (4920)	4.7 (120)	4.7 (120)	4.25	8	4850 (2200)
	159 (4040)	111.6 (2835)	188.8 (4795)	205.5 (5220)	4.7 (120)	4.7 (120)	4.25	8	4850 (2200)
	179 (4540)	121.5 (3085)	208.5 (5295)	225.2 (5720)	4.7 (120)	4.7 (120)	4.25	6	4850 (2200)
Full Free-Lift 2-Stage (FV)	119.5 (3040)	84.1 (2135)	144.6 (3674)	168.9 (4289)	59.1 (1501)	34.9 (886)	4.25	8	4850 (2200)
	131.5 (3340)	88 (2235)	156.5 (3974)	180.7 (4589)	63 (1601)	38.8 (986)	4.25	8	4850 (2200)
	147 (3740)	101.8 (2585)	172.2 (4374)	196.4 (4989)	76.8 (1951)	52.6 (1336)	4.25	8	4850 (2200)
Full Free-Lift 2-Stage, 4-Cylinder (FW)	119.5 (3040)	82.9 (2105)	141.9 (3605)	166.1 (4220)	59.1 (1500)	36.4 (925)	4.25	8	4850 (2200)
	131.5 (3340)	88 (2235)	153.7 (3905)	178 (4520)	64.2 (1630)	41.5 (1055)	4.25	8	4850 (2200)
	147 (3740)	98.6 (2505)	169.5 (4305)	193.7 (4920)	74.8 (1900)	52.2 (1325)	4.25	8	4850 (2200)
Full Free-Lift 3-Stage (FSV)	159 (4040)	104.5 (2655)	181.3 (4605)	205.5 (5220)	80.7 (2050)	58.1 (1475)	4.25	8	4850 (2200)
	171 (4340)	84.1 (2135)	195.8 (4974)	220 (5589)	57.5 (1461)	34.9 (886)	4.25	6	4850 (2200)
	186.5 (4740)	88 (2235)	211.6 (5374)	235.8 (5989)	61.5 (1561)	38.8 (986)	4.25	6	4850 (2200)
	198 (5040)	94.3 (2395)	223.4 (5674)	247.6 (6289)	67.8 (1721)	45.1 (1146)	4.25	6	4850 (2200)
	218 (5540)	101.8 (2585)	243.1 (6174)	267.3 (6789)	75.2 (1911)	52.6 (1336)	4.25	6	4850 (2200)
Full Free-Lift 3-Stage, 4-Cylinder (FSW)	238 (6040)	111.6 (2835)	262.8 (6674)	287 (7289)	85.1 (2161)	62.4 (1586)	4.25	6	4850 (2200)
	257 (6540)	121.5 (3085)	282.4 (7174)	306.7 (7789)	94.9 (2411)	72.3 (1836)	4.25	6	4300 (1950)
	173 (4390)	82.9 (2105)	195.1 (4955)	219.3 (5570)	59.1 (1500)	36.4 (925)	4.25	6	4850 (2200)
	186.5 (4740)	86.8 (2205)	208.6 (5305)	233.1 (5920)	63 (1600)	40.4 (1025)	4.25	6	4850 (2200)
	198 (5040)	90.7 (2305)	220.7 (5605)	244.9 (6220)	66.9 (1700)	44.3 (1125)	4.25	6	4850 (2200)
Full Free-Lift 3-Stage, 4-Cylinder (FSW)	218 (5540)	98.6 (2505)	240.4 (6105)	264.6 (6720)	74.8 (1900)	52.2 (1325)	4.25	6	4850 (2200)
	238 (6040)	104.5 (2655)	260.3 (6605)	284.3 (7220)	80.7 (2050)	58.1 (1475)	4.25	6	4850 (2200)
	257 (6540)	112.4 (2855)	279.7 (7105)	303.9 (7720)	88.6 (2250)	65.9 (1675)	4.25	6	4320 (1960)

MAST TYPE	MAXIMUM FORK HEIGHT (TOP OF FORKS)	OVERALL HEIGHT			FREE-LIFT		TILT RANGE		LOAD CAPACITY AT
		LOWERED	EXTENDED		WITHOUT LOAD BACKREST	WITH STANDARD LOAD BACKREST ¹	FWD	BWD	24 IN. (610 MM) LOAD CENTER*
			WITHOUT LOAD BACKREST	WITH STANDARD LOAD BACKREST ¹					lb (kg)
	in (mm)	in (mm)	in (mm)	in (mm)	in (mm)	in (mm)	deg	deg	lb (kg)
05-9FBH25T									
Wide Visible (V)	119.5 (3040)	86.8 (2205)	143.7 (3650)	166 (4215)	4.9 (125)	4.9 (125)	4.25	8	5510 (2500)
	131.5 (3340)	92.7 (2355)	155.5 (3950)	177.8 (4515)	4.9 (125)	4.9 (125)	4.25	8	5510 (2500)
	147 (3740)	100.6 (2555)	171.3 (4350)	193.5 (4915)	4.9 (125)	4.9 (125)	4.25	8	5510 (2500)
	159 (4040)	108.5 (2755)	185.6 (4715)	205.3 (5215)	4.9 (125)	4.9 (125)	4.25	8	5510 (2500)
	179 (4540)	120.3 (3055)	207.3 (5265)	225 (5715)	4.9 (125)	4.9 (125)	4.25	6	5510 (2500)
Full Free-Lift 2-Stage (FV)	119.5 (3040)	84.1 (2135)	146.9 (3730)	169.1 (4295)	55.3 (1405)	34.8 (885)	4.25	8	5510 (2500)
	131.5 (3340)	88.8 (2255)	158.7 (4030)	180.9 (4595)	60 (1525)	39.6 (1005)	4.25	8	5510 (2500)
	147 (3740)	101.8 (2585)	174.4 (4430)	196.7 (4995)	73 (1855)	52.6 (1335)	4.25	8	5510 (2500)
Full Free-Lift 2-Stage, 4-Cylinder (FW)	159 (4040)	111.6 (2835)	186.2 (4730)	208.5 (5295)	82.9 (2105)	62.4 (1585)	4.25	8	5510 (2500)
	119.5 (3040)	86.8 (2205)	143.9 (3655)	166.1 (4220)	61.6 (1565)	40.6 (1030)	4.25	8	5510 (2500)
	131.5 (3340)	92.7 (2355)	155.7 (3955)	178 (4520)	67.5 (1715)	46.5 (1180)	4.25	8	5510 (2500)
Full Free-Lift 3-Stage (FSV)	147 (3740)	100.4 (2550)	171.5 (4355)	193.7 (4920)	75.4 (1915)	54.3 (1380)	4.25	8	5510 (2500)
	159 (4040)	108.5 (2755)	183.3 (4655)	205.5 (5220)	83.3 (2115)	62.2 (1580)	4.25	8	5510 (2500)
	171 (4340)	84.1 (2135)	194.1 (4930)	216.3 (5495)	59.3 (1505)	38.8 (985)	4.25	6	5510 (2500)
	186.5 (4740)	88 (2235)	209.4 (5320)	231.7 (5885)	63.2 (1605)	42.7 (1085)	4.25	6	5510 (2500)
	198 (5040)	94.3 (2395)	221.7 (5630)	243.9 (6195)	69.5 (1765)	49 (1245)	4.25	6	5510 (2500)
Full Free-Lift 3-Stage, 4-Cylinder (FSW)	218 (5540)	101.8 (2585)	241.3 (6130)	263.6 (6695)	77 (1955)	56.5 (1435)	4.25	6	5400 (2450)
	238 (6040)	111.6 (2835)	261 (6630)	283.3 (7195)	86.8 (2205)	63.3 (1685)	4.25	6	5225 (2370)
	257 (6540)	121.5 (3085)	280.7 (7130)	303 (7695)	96.7 (2455)	76.2 (1935)	4.25	6	5070 (2300)
	173 (4390)	86.8 (2205)	196.9 (5000)	219.1 (5565)	61.2 (1555)	40.7 (1035)	4.25	6	5510 (2500)
	186.5 (4740)	90.7 (2305)	210.6 (5350)	232.9 (5915)	65.2 (1655)	44.7 (1135)	4.25	6	5510 (2500)
Full Free-Lift 3-Stage, 4-Cylinder (FSW)	198 (5040)	94.7 (2405)	222.4 (5650)	244.7 (6215)	69.1 (1755)	48.6 (1235)	4.25	6	5510 (2500)
	218 (5540)	100.6 (2555)	242.1 (6150)	264.4 (6715)	75 (1905)	54.5 (1385)	4.25	6	5400 (2450)
	238 (6040)	108.5 (2755)	261.8 (6650)	284.1 (7215)	82.9 (2105)	62.4 (1585)	4.25	6	5225 (2370)
257 (6540)	116.3 (2955)	281.5 (7150)	303.7 (7715)	90.7 (2305)	70.3 (1785)	4.25	6	5070 (2300)	

¹ Height of standard load backrest is 48" (1220 mm)
* All capacities of 1,500 lbs or less are subject to a secondary review and could be denied by Toyota

MAST SPECIFICATIONS

MAST TYPE	MAXIMUM FORK HEIGHT (TOP OF FORKS)	OVERALL HEIGHT				FREE-LIFT		TILT RANGE		LOAD CAPACITY AT
		LOWERED	EXTENDED		WITHOUT LOAD BACKREST	WITH STANDARD LOAD BACKREST ¹	FWD	BWD	24 IN. (610 MM) LOAD CENTER*	
			WITHOUT LOAD BACKREST	WITH STANDARD LOAD BACKREST ¹						in (mm)
	in (mm)	in (mm)	in (mm)	in (mm)	in (mm)	in (mm)	deg	deg	lb (kg)	
05-9FBMK30T										
Wide Visible (V)	119.5 (3040)	87.2 (2215)	145.9 (3705)	167.7 (4260)	4.9 (125)	4.9 (125)	4.25	8	5975 (2710)	
	131.5 (3340)	94.3 (2395)	159.3 (4045)	179.5 (4560)	4.9 (125)	4.9 (125)	4.25	8	5975 (2710)	
	147 (3740)	101.8 (2585)	175 (4445)	195.3 (4960)	4.9 (125)	4.9 (125)	4.25	8	5975 (2710)	
	159 (4040)	111.6 (2835)	186.8 (4745)	207.1 (5260)	4.9 (125)	4.9 (125)	4.25	8	5975 (2710)	
Full Free-Lift 2-Stage (FV)	119.5 (3040)	84.1 (2135)	146.9 (3730)	169.1 (4295)	55.3 (1405)	34.8 (885)	4.25	8	5975 (2710)	
	131.5 (3340)	88.8 (2255)	158.7 (4030)	180.9 (4595)	60 (1525)	39.6 (1005)	4.25	8	5975 (2710)	
	147 (3740)	101.8 (2585)	174.4 (4430)	196.7 (4995)	73 (1855)	52.6 (1335)	4.25	8	5975 (2710)	
Full Free-Lift 2-Stage, 4-Cylinder (FW)	119.5 (3040)	86.8 (2205)	143.9 (3655)	166.1 (4220)	61.6 (1565)	40.6 (1030)	4.25	8	5975 (2710)	
	131.5 (3340)	92.7 (2355)	155.7 (3955)	178 (4520)	67.5 (1715)	46.5 (1180)	4.25	8	5975 (2710)	
	147 (3740)	100.4 (2550)	171.5 (4355)	193.7 (4920)	75.4 (1915)	54.3 (1380)	4.25	8	5975 (2710)	
Full Free-Lift 3-Stage (FSV)	171 (4340)	84.1 (2135)	194.1 (4930)	216.3 (5495)	59.3 (1505)	38.8 (985)	4.25	6	5620 (2550)	
	186.5 (4740)	88 (2235)	209.4 (5320)	231.7 (5885)	63.2 (1605)	42.7 (1085)	4.25	6	5620 (2550)	
	198 (5040)	94.3 (2395)	221.7 (5630)	243.9 (6195)	69.5 (1765)	49.0 (1245)	4.25	6	5620 (2550)	
	218 (5540)	101.8 (2585)	241.3 (6130)	263.6 (6695)	77 (1955)	56.5 (1435)	4.25	6	5375 (2440)	
	238 (6040)	111.6 (2835)	261.0 (6630)	283.3 (7195)	86.8 (2205)	66.3 (1685)	4.25	6	5070 (2300)	
Full Free-Lift 3-Stage, 4-Cylinder (FSW)	257 (6540)	121.5 (3085)	280.7 (7130)	303.0 (7695)	96.7 (2455)	76.2 (1935)	4.25	6	4650 (2110)	
	173 (4390)	86.8 (2205)	196.9 (5000)	219.1 (5565)	61.2 (1555)	40.7 (1035)	4.25	6	5885 (2670)	
	186.5 (4740)	90.7 (2305)	210.6 (5350)	232.9 (5915)	65.2 (1655)	44.7 (1135)	4.25	6	5885 (2670)	
	198 (5040)	94.7 (2405)	222.4 (5650)	244.7 (6215)	69.1 (1755)	48.6 (1235)	4.25	6	5640 (2560)	
	218 (5540)	98.6 (2505)	242.1 (6150)	264.4 (6715)	75 (1905)	54.5 (1385)	4.25	6	5375 (2440)	
238 (6040)	108.5 (2755)	261.8 (6650)	284.1 (7215)	82.9 (2105)	62.4 (1585)	4.25	6	5070 (2300)		
257 (6540)	116.3 (2955)	281.5 (7150)	303.7 (7715)	90.7 (2305)	70.3 (1785)	4.25	6	4650 (2110)		

MAST TYPE	MAXIMUM FORK HEIGHT (TOP OF FORKS)	OVERALL HEIGHT				FREE-LIFT		TILT RANGE		LOAD CAPACITY AT
		LOWERED	EXTENDED		WITHOUT LOAD BACKREST	WITH STANDARD LOAD BACKREST ¹	FWD	BWD	24 IN. (610 MM) LOAD CENTER*	
			WITHOUT LOAD BACKREST	WITH STANDARD LOAD BACKREST ¹						in (mm)
	in (mm)	in (mm)	in (mm)	in (mm)	in (mm)	in (mm)	deg	deg	lb (kg)	
05-9FBM30T										
Wide Visible (V)	119.5 (3040)	87.2 (2215)	145.9 (3705)	167.7 (4260)	4.9 (125)	4.9 (125)	4.25	8	5975 (2710)	
	131.5 (3340)	94.3 (2395)	159.3 (4045)	179.5 (4560)	4.9 (125)	4.9 (125)	4.25	8	5975 (2710)	
	147 (3740)	101.8 (2585)	175 (4445)	195.3 (4960)	4.9 (125)	4.9 (125)	4.25	8	5975 (2710)	
	159 (4040)	111.6 (2835)	186.8 (4745)	207.1 (5260)	4.9 (125)	4.9 (125)	4.25	8	5975 (2710)	
Full Free-Lift 2-Stage (FV)	119.5 (3040)	84.1 (2135)	146.9 (3730)	169.1 (4295)	55.3 (1405)	34.8 (885)	4.25	8	5975 (2710)	
	131.5 (3340)	88.8 (2255)	158.7 (4030)	180.9 (4595)	60 (1525)	39.6 (1005)	4.25	8	5975 (2710)	
	147 (3740)	101.8 (2585)	174.4 (4430)	196.7 (4995)	73 (1855)	52.6 (1335)	4.25	8	5975 (2710)	
Full Free-Lift 2-Stage, 4-Cylinder (FW)	119.5 (3040)	86.8 (2205)	143.9 (3655)	166.1 (4220)	61.6 (1565)	40.6 (1030)	4.25	8	5975 (2710)	
	131.5 (3340)	92.7 (2355)	155.7 (3955)	178 (4520)	67.5 (1715)	46.5 (1180)	4.25	8	5975 (2710)	
	147 (3740)	100.4 (2550)	171.5 (4355)	193.7 (4920)	75.4 (1915)	54.3 (1380)	4.25	8	5975 (2710)	
Full Free-Lift 3-Stage (FSV)	171 (4340)	84.1 (2135)	194.1 (4930)	216.3 (5495)	59.3 (1505)	38.8 (985)	4.25	6	5620 (2550)	
	186.5 (4740)	88 (2235)	209.4 (5320)	231.7 (5885)	63.2 (1605)	42.7 (1085)	4.25	6	5620 (2550)	
	198 (5040)	94.3 (2395)	221.7 (5630)	243.9 (6195)	69.5 (1765)	49.0 (1245)	4.25	6	5620 (2550)	
	218 (5540)	101.8 (2585)	241.3 (6130)	263.6 (6695)	77 (1955)	56.5 (1435)	4.25	6	5490 (2490)	
	238 (6040)	111.6 (2835)	261.0 (6630)	283.3 (7195)	86.8 (2205)	66.3 (1685)	4.25	6	5265 (2390)	
Full Free-Lift 3-Stage, 4-Cylinder (FSW)	257 (6540)	121.5 (3085)	280.7 (7130)	303.0 (7695)	96.7 (2455)	76.2 (1935)	4.25	6	5070 (2300)	
	173 (4390)	86.8 (2205)	196.9 (5000)	219.1 (5565)	61.2 (1555)	40.7 (1035)	4.25	6	5985 (2720)	
	186.5 (4740)	90.7 (2305)	210.6 (5350)	232.9 (5915)	65.2 (1655)	44.7 (1135)	4.25	6	5885 (2670)	
	198 (5040)	94.7 (2405)	222.4 (5650)	244.7 (6215)	69.1 (1755)	48.6 (1235)	4.25	6	5750 (2610)	
	218 (5540)	98.6 (2505)	242.1 (6150)	264.4 (6715)	75 (1905)	54.5 (1385)	4.25	6	5490 (2490)	
238 (6040)	108.5 (2755)	261.8 (6650)	284.1 (7215)	82.9 (2105)	62.4 (1585)	4.25	6	5265 (2390)		
257 (6540)	116.3 (2955)	281.5 (7150)	303.7 (7715)	90.7 (2305)	70.3 (1785)	4.25	6	5070 (2300)		

¹ Height of standard load backrest is 48" (1220 mm)
 * All capacities of 1,500 lbs or less are subject to a secondary review and could be denied by Toyota



MAST SPECIFICATIONS

MAST TYPE	MAXIMUM FORK HEIGHT (TOP OF FORKS)	OVERALL HEIGHT				FREE-LIFT		TILT RANGE		LOAD CAPACITY AT
		LOWERED	EXTENDED		WITHOUT LOAD BACKREST	WITH STANDARD LOAD BACKREST ¹	FWD	BWD	24 IN. (610 MM) LOAD CENTER*	
			WITHOUT LOAD BACKREST	WITH STANDARD LOAD BACKREST ¹						deg
	in (mm)	in (mm)	in (mm)	in (mm)	in (mm)	in (mm)	deg	deg	lb (kg)	
05-9FBH30T										
Wide Visible (V)	119.5 (3040)	86.8 (2205)	143.7 (3650)	166 (4215)	4.9 (125)	4.9 (125)	4.25	8	6610 (3000)	
	131.5 (3340)	92.7 (2355)	155.5 (3950)	177.8 (4515)	4.9 (125)	4.9 (125)	4.25	8	6610 (3000)	
	147 (3740)	100.6 (2555)	171.3 (4350)	193.5 (4915)	4.9 (125)	4.9 (125)	4.25	8	6610 (3000)	
	159 (4040)	108.5 (2755)	185.6 (4715)	205.3 (5215)	4.9 (125)	4.9 (125)	4.25	8	6610 (3000)	
Full Free-Lift 2-Stage (FV)	119.5 (3040)	87.2 (2215)	146.9 (3730)	169.1 (4295)	58.5 (1485)	38 (965)	4.25	8	6610 (3000)	
	131.5 (3340)	94.3 (2395)	158.7 (4030)	180.9 (4595)	65.6 (1665)	45.1 (1145)	4.25	8	6610 (3000)	
	147 (3740)	111.6 (2835)	174.4 (4430)	196.7 (4995)	82.9 (2105)	62.4 (1585)	4.25	8	6610 (3000)	
Full Free-Lift 2-Stage, 4-Cylinder (FW)	119.5 (3040)	86.8 (2205)	143.9 (3655)	166.1 (4220)	61.6 (1565)	40.6 (1030)	4.25	8	6610 (3000)	
	131.5 (3340)	92.7 (2355)	155.7 (3955)	178 (4520)	67.5 (1715)	46.5 (1180)	4.25	8	6610 (3000)	
	147 (3740)	100.6 (2555)	171.5 (4355)	193.7 (4920)	75.4 (1915)	54.3 (1380)	4.25	8	6610 (3000)	
	159 (4040)	108.5 (2755)	183.3 (4655)	205.5 (5220)	83.3 (2115)	62.2 (1580)	4.25	8	6610 (3000)	
Full Free-Lift 3-Stage (FSV)	171 (4340)	87.2 (2215)	198 (5030)	220.3 (5595)	58.5 (1485)	38 (965)	4.25	6	6610 (3000)	
	186.5 (4740)	94.3 (2395)	213.8 (5430)	236 (5995)	65.6 (1665)	45.1 (1145)	4.25	6	6610 (3000)	
	198 (5040)	101.8 (2585)	225.6 (5730)	247.8 (6295)	73 (1855)	52.6 (1335)	4.25	6	6610 (3000)	
	218 (5540)	111.6 (2835)	245.3 (6230)	267.5 (6795)	82.9 (2105)	62.4 (1585)	4.25	6	6500 (2950)	
	238 (6040)	121.5 (3085)	265 (6730)	287.2 (7295)	92.7 (2355)	72.2 (1835)	4.25	6	6280 (2850)	
Full Free-Lift 3-Stage, 4-Cylinder (FSW)	257 (6540)	131.3 (3335)	284.6 (7230)	306.9 (7795)	102.6 (2605)	82.1 (2085)	4.25	6	6015 (2730)	
	173 (4390)	86.8 (2205)	196.9 (5000)	219.1 (5565)	61.2 (1555)	40.7 (1035)	4.25	6	6610 (3000)	
	186.5 (4740)	90.7 (2305)	210.6 (5350)	232.9 (5915)	65.2 (1655)	44.7 (1135)	4.25	6	6610 (3000)	
	198 (5040)	94.7 (2405)	222.4 (5650)	244.7 (6215)	69.1 (1755)	48.6 (1235)	4.25	6	6610 (3000)	
	218 (5540)	100.6 (2555)	242.1 (6150)	264.4 (6715)	75 (1905)	54.5 (1385)	4.25	6	6500 (2950)	
	238 (6040)	108.5 (2755)	261.8 (6650)	284.1 (7215)	82.9 (2105)	62.4 (1585)	4.25	6	6280 (2850)	
	257 (6540)	116.3 (2955)	281.5 (7150)	303.7 (7715)	90.7 (2305)	70.3 (1785)	4.25	6	6060 (2750)	

MAST TYPE	MAXIMUM FORK HEIGHT (TOP OF FORKS)	OVERALL HEIGHT				FREE-LIFT		TILT RANGE		LOAD CAPACITY AT
		LOWERED	EXTENDED		WITHOUT LOAD BACKREST	WITH STANDARD LOAD BACKREST ¹	FWD	BWD	24 IN. (610 MM) LOAD CENTER*	
			WITHOUT LOAD BACKREST	WITH STANDARD LOAD BACKREST ¹						deg
	in (mm)	in (mm)	in (mm)	in (mm)	in (mm)	in (mm)	deg	deg	lb (kg)	
05-9FBM35T										
Wide Visible (V)	119.5 (3040)	87.2 (2215)	145.5 (3695)	167.7 (4260)	4.9 (125)	4.9 (125)	4.25	8	6610 (3000)	
	131.5 (3340)	94.3 (2395)	158.9 (4035)	179.5 (4560)	4.9 (125)	4.9 (125)	4.25	8	6610 (3000)	
	147 (3740)	101.8 (2585)	174.6 (4435)	195.3 (4960)	4.9 (125)	4.9 (125)	4.25	8	6610 (3000)	
	159 (4040)	111.6 (2835)	188.8 (4795)	207.1 (5260)	4.9 (125)	4.9 (125)	4.25	8	6610 (3000)	
	179 (4540)	121.5 (3085)	208.5 (5295)	226.8 (5760)	4.9 (125)	4.9 (125)	4.25	6	6610 (3000)	
Full Free-Lift 2-Stage (FV)	119.5 (3040)	87.2 (2215)	146.9 (3730)	169.1 (4295)	58.5 (1485)	38 (965)	4.25	8	6610 (3000)	
	131.5 (3340)	94.3 (2395)	158.7 (4030)	180.9 (4595)	65.6 (1665)	45.1 (1145)	4.25	8	6610 (3000)	
	147 (3740)	111.6 (2835)	174.4 (4430)	196.7 (4995)	82.9 (2105)	62.4 (1585)	4.25	8	6610 (3000)	
	159 (4040)	121.5 (3085)	186.2 (4730)	208.5 (5295)	92.7 (2355)	72.2 (1835)	4.25	8	6610 (3000)	
Full Free-Lift 2-Stage, 4-Cylinder (FW)	119.5 (3040)	86.8 (2205)	143.9 (3655)	166.1 (4220)	61.6 (1565)	40.6 (1030)	4.25	8	6610 (3000)	
	131.5 (3340)	92.7 (2355)	155.7 (3955)	178 (4520)	67.5 (1715)	46.5 (1180)	4.25	8	6610 (3000)	
	147 (3740)	100.4 (2550)	171.5 (4355)	193.7 (4920)	75.4 (1915)	54.3 (1380)	4.25	8	6610 (3000)	
	159 (4040)	108.5 (2755)	183.3 (4655)	205.5 (5220)	83.3 (2115)	62.2 (1580)	4.25	8	6610 (3000)	
Full Free-Lift 3-Stage (FSV)	171 (4340)	87.2 (2215)	198 (5030)	220.3 (5595)	58.5 (1485)	38 (965)	4.25	6	6830 (3100)	
	186.5 (4740)	94.3 (2395)	213.8 (5430)	236 (5995)	65.6 (1665)	45.1 (1145)	4.25	6	6830 (3100)	
	198 (5040)	101.8 (2585)	225.6 (5730)	247.8 (6295)	73 (1855)	52.6 (1335)	4.25	6	6830 (3100)	
	218 (5540)	111.6 (2835)	245.3 (6230)	267.5 (6795)	82.9 (2105)	62.4 (1585)	4.25	6	6610 (3000)	
	238 (6040)	121.5 (3085)	265 (6730)	287.2 (7295)	92.7 (2355)	72.2 (1835)	4.25	6	5730 (2600)	
Full Free-Lift 3-Stage, 4-Cylinder (FSW)	257 (6540)	131.3 (3335)	284.6 (7230)	306.9 (7795)	102.6 (2605)	82.1 (2085)	4.25	8	5465 (2480)	
	173 (4390)	86.8 (2205)	196.9 (5000)	219.1 (5565)	61.2 (1555)	40.7 (1035)	4.25	8	6830 (3100)	
	186.5 (4740)	90.7 (2305)	210.6 (5350)	232.9 (5915)	65.2 (1655)	44.7 (1135)	4.25	8	6830 (3100)	
	198 (5040)	94.7 (2405)	222.4 (5650)	244.7 (6215)	69.1 (1755)	48.6 (1235)	4.25	8	6830 (3100)	
	218 (5540)	98.6 (2505)	242.1 (6150)	264.4 (6715)	75 (1905)	54.5 (1385)	4.25	8	6610 (3000)	
	238 (6040)	108.5 (2755)	261.8 (6650)	284.1 (7215)	82.9 (2105)	62.4 (1585)	4.25	8	5730 (2600)	
	257 (6540)	116.3 (2955)	281.5 (7150)	303.7 (7715)	90.7 (2305)	70.3 (1785)	4.25	8	5465 (2480)	

¹ Height of standard load backrest is 48" (1220 mm)
 * All capacities of 1,500 lbs or less are subject to a secondary review and could be denied by Toyota

MAST TYPE	MAXIMUM FORK HEIGHT (TOP OF FORKS)	OVERALL HEIGHT			FREE-LIFT		TILT RANGE		LOAD CAPACITY AT
		LOWERED	EXTENDED		WITHOUT LOAD BACKREST	WITH STANDARD LOAD BACKREST ¹	FWD	BWD	24 IN. (610 MM) LOAD CENTER*
			WITHOUT LOAD BACKREST	WITH STANDARD LOAD BACKREST ¹					
	in (mm)	in (mm)	in (mm)	in (mm)	in (mm)	in (mm)	deg	deg	lb (kg)
05-8FBM40T									
Wide Visible (V)	120 (3050)	92.9 (2360)	151.8 (3856)	165.4 (4200)	3.15 (80)	3.15 (80)	5	10	8000 (3640)
	132 (3350)	98.4 (2500)	163.6 (4156)	177.2 (4500)	3.15 (80)	3.15 (80)	5	10	8000 (3640)
	147.5 (3750)	108.3 (2750)	179.5 (4560)	192.9 (4900)	3.15 (80)	3.15 (80)	5	10	8000 (3640)
	159 (4050)	113.4 (2880)	191.2 (4856)	204.7 (5200)	3.15 (80)	3.15 (80)	5	10	8000 (3640)
	179 (4550)	123.2 (3130)	210.9 (5356)	224.4 (5700)	3.15 (80)	3.15 (80)	5	6	8000 (3640)
	199 (5050)	133.1 (3380)	230.6 (5856)	244.1 (6200)	3.15 (80)	3.15 (80)	5	6	8000 (3640)
Full Free-Lift 2-Stage (FV)	218.5 (5550)	142.9 (3630)	250.2 (6356)	263.8 (6700)	3.15 (80)	3.15 (80)	5	6	7914 (3590)
	120 (3050)	92.9 (2360)	153.1 (3890)	165.4 (4200)	57.9 (1470)	45.7 (1160)	5	10	8000 (3640)
	132 (3350)	98.4 (2500)	165 (4190)	177.2 (4500)	63.4 (1610)	48.8 (1240)	5	10	8000 (3640)
	147.5 (3750)	108.3 (2750)	180.7 (4590)	192.9 (4900)	73.2 (1860)	51.2 (1300)	5	10	8000 (3640)
Full Free-Lift 2-Stage, 4-Cylinder (FW)	159 (4050)	113.4 (2880)	192.5 (4890)	204.7 (5200)	78.3 (1990)	61 (1550)	5	10	8000 (3640)
	120 (3050)	92.9 (2360)	153.1 (3890)	165.4 (4200)	57.9 (1470)	45.7 (1160)	5	10	8000 (3640)
	132 (3350)	98.4 (2500)	165 (4190)	177.2 (4500)	63.4 (1610)	48.8 (1240)	5	10	8000 (3640)
	147.5 (3750)	108.3 (2750)	180.7 (4590)	192.9 (4900)	73.2 (1860)	51.2 (1300)	5	10	8000 (3640)
Full Free-Lift 3-Stage (FSV)	159 (4050)	113.4 (2880)	192.5 (4890)	204.7 (5200)	78.3 (1990)	61 (1550)	5	10	8000 (3640)
	175 (4450)	92.9 (2360)	208.3 (5290)	220.5 (5600)	57.9 (1470)	45.7 (1160)	5	6	8000 (3640)
	187 (4750)	96.1 (2440)	220.1 (5590)	232.3 (5900)	61 (1550)	48.8 (1240)	5	6	8000 (3640)
	199 (5050)	98.4 (2500)	231.9 (5890)	244.1 (6200)	63.4 (1610)	51.2 (1300)	5	6	8000 (3640)
Full Free-Lift 3-Stage, 4-Cylinder (FSW)	218.5 (5550)	108.3 (2750)	251.6 (6390)	263.8 (6700)	73.2 (1860)	61 (1550)	5	6	7716 (3500)
	238 (6050)	113.4 (2880)	271.3 (6890)	283.5 (7200)	78.3 (1990)	66.1 (1680)	5	6	7430 (3370)
	258 (6550)	123.2 (3130)	290.9 (7390)	303.1 (7700)	88.2 (2240)	76 (1930)	5	6	6812 (3090)
	175 (4450)	92.9 (2360)	208.3 (5290)	220.5 (5600)	57.9 (1470)	45.7 (1160)	5	6	8000 (3640)

MAST TYPE	MAXIMUM FORK HEIGHT (TOP OF FORKS)	OVERALL HEIGHT			FREE-LIFT		TILT RANGE		LOAD CAPACITY AT
		LOWERED	EXTENDED		WITHOUT LOAD BACKREST	WITH STANDARD LOAD BACKREST ¹	FWD	BWD	24 IN. (610 MM) LOAD CENTER*
			WITHOUT LOAD BACKREST	WITH STANDARD LOAD BACKREST ¹					
	in (mm)	in (mm)	in (mm)	in (mm)	in (mm)	in (mm)	deg	deg	lb (kg)
05-8FBM45T									
Wide Visible (V)	120 (3050)	92.9 (2360)	151.8 (3856)	165.4 (4200)	3.15 (80)	3.15 (80)	5	10	9000 (4090)
	132 (3350)	98.4 (2500)	163.6 (4156)	177.2 (4500)	3.15 (80)	3.15 (80)	5	10	9000 (4090)
	147.5 (3750)	108.3 (2750)	179.5 (4560)	192.9 (4900)	3.15 (80)	3.15 (80)	5	10	9000 (4090)
	159 (4050)	113.4 (2880)	191.2 (4856)	204.7 (5200)	3.15 (80)	3.15 (80)	5	10	9000 (4090)
	179 (4550)	123.2 (3130)	210.9 (5356)	224.4 (5700)	3.15 (80)	3.15 (80)	5	6	9000 (4090)
	199 (5050)	133.1 (3380)	230.6 (5856)	244.1 (6200)	3.15 (80)	3.15 (80)	5	6	9000 (4090)
Full Free-Lift 2-Stage (FV)	218.5 (5550)	142.9 (3630)	250.2 (6356)	263.8 (6700)	3.15 (80)	3.15 (80)	5	6	8928 (4050)
	120 (3050)	92.9 (2360)	153.1 (3890)	165.4 (4200)	57.9 (1470)	45.7 (1160)	5	10	9000 (4090)
	132 (3350)	98.4 (2500)	165 (4190)	177.2 (4500)	63.4 (1610)	48.8 (1240)	5	10	9000 (4090)
	147.5 (3750)	108.3 (2750)	180.7 (4590)	192.9 (4900)	73.2 (1860)	51.2 (1300)	5	10	9000 (4090)
Full Free-Lift 2-Stage, 4-Cylinder (FW)	159 (4050)	113.4 (2880)	192.5 (4890)	204.7 (5200)	78.3 (1990)	61 (1550)	5	10	9000 (4090)
	120 (3050)	92.9 (2360)	153.1 (3890)	165.4 (4200)	57.9 (1470)	45.7 (1160)	5	10	9000 (4090)
	132 (3350)	98.4 (2500)	165 (4190)	177.2 (4500)	63.4 (1610)	48.8 (1240)	5	10	9000 (4090)
	147.5 (3750)	108.3 (2750)	180.7 (4590)	192.9 (4900)	73.2 (1860)	51.2 (1300)	5	10	9000 (4090)
Full Free-Lift 3-Stage (FSV)	159 (4050)	113.4 (2880)	192.5 (4890)	204.7 (5200)	78.3 (1990)	61 (1550)	5	10	9000 (4090)
	175 (4450)	92.9 (2360)	208.3 (5290)	220.5 (5600)	57.9 (1470)	45.7 (1160)	5	6	9000 (4090)
	187 (4750)	96.1 (2440)	220.1 (5590)	232.3 (5900)	61 (1550)	48.8 (1240)	5	6	9000 (4090)
	199 (5050)	98.4 (2500)	231.9 (5890)	244.1 (6200)	63.4 (1610)	51.2 (1300)	5	6	8818 (4000)
Full Free-Lift 3-Stage, 4-Cylinder (FSW)	218.5 (5550)	108.3 (2750)	251.6 (6390)	263.8 (6700)	73.2 (1860)	61 (1550)	5	6	8708 (3950)
	238 (6050)	113.4 (2880)	271.3 (6890)	283.5 (7200)	78.3 (1990)	66.1 (1680)	5	6	8443 (3830)
	258 (6550)	123.2 (3130)	290.9 (7390)	303.1 (7700)	88.2 (2240)	76 (1930)	5	6	7319 (3320)
	175 (4450)	92.9 (2360)	208.3 (5290)	220.5 (5600)	57.9 (1470)	45.7 (1160)	5	6	9000 (4090)

¹ Height of standard load backrest is 48" (1220 mm)

* All capacities of 1,500 lbs or less are subject to a secondary review and could be denied by Toyota

MAST SPECIFICATIONS

MAST TYPE	MAXIMUM FORK HEIGHT (TOP OF FORKS)	OVERALL HEIGHT			FREE-LIFT		TILT RANGE		LOAD CAPACITY AT
		LOWERED	EXTENDED		WITHOUT LOAD BACKREST	WITH STANDARD LOAD BACKREST ¹	FWD	BWD	24 IN. (610 MM) LOAD CENTER*
			WITHOUT LOAD BACKREST	WITH STANDARD LOAD BACKREST ¹					
05-8FBM50T									
Wide Visible (V)	120 (3060)	92.9 (2360)	155.7 (3956)	165.4 (4200)	3.15 (80)	3.15 (80)	5	10	11000 (4990)
	132 (3360)	98.4 (2500)	163.6 (4156)	177.2 (4500)	3.15 (80)	3.15 (80)	5	10	11000 (4990)
	148 (3760)	108.3 (2750)	179.5 (4560)	192.9 (4900)	3.15 (80)	3.15 (80)	5	10	11000 (4990)
	160 (4060)	113.4 (2880)	191.2 (4856)	204.7 (5200)	3.15 (80)	3.15 (80)	5	10	11000 (4990)
	179.5 (4560)	123.2 (3130)	210.9 (5356)	224.4 (5700)	3.15 (80)	3.15 (80)	5	6	11000 (4990)
	199 (5060)	133.1 (3380)	230.6 (5856)	244.1 (6200)	3.15 (80)	3.15 (80)	5	6	11000 (4990)
Full Free-Lift 2-Stage (FV)	219 (5560)	142.9 (3630)	250.2 (6356)	263.8 (6700)	3.15 (80)	3.15 (80)	5	6	10913 (4950)
	112.5 (2860)	92.9 (2360)	145.3 (3690)	157.5 (4000)	57.9 (1470)	45.7 (1160)	5	10	11000 (4990)
	132 (3360)	103.5 (2630)	165 (4190)	177.2 (4500)	68.5 (1740)	56.3 (1430)	5	10	11000 (4990)
Full Free-Lift 2-Stage, 4-Cylinder (FW)	148 (3760)	113.4 (2880)	180.7 (4590)	192.9 (4900)	78.3 (1990)	66.1 (1680)	5	10	11000 (4990)
	160 (4060)	123.2 (3130)	192.5 (4890)	204.7 (5200)	88.2 (2240)	76 (1930)	5	10	11000 (4990)
	112.5 (2860)	92.9 (2360)	145.3 (3690)	157.5 (4000)	57.9 (1470)	45.7 (1160)	5	10	11000 (4990)
Full Free-Lift 3-Stage (FSV)	132 (3360)	103.5 (2630)	165 (4190)	177.2 (4500)	68.5 (1740)	56.3 (1430)	5	10	11000 (4990)
	148 (3760)	113.4 (2880)	180.7 (4590)	192.9 (4900)	78.3 (1990)	66.1 (1680)	5	10	11000 (4990)
	160 (4060)	123.2 (3130)	192.5 (4890)	204.7 (5200)	88.2 (2240)	76 (1930)	5	10	11000 (4990)
	171.5 (4360)	92.9 (2360)	204.3 (5190)	216.5 (5500)	57.9 (1470)	45.7 (1160)	5	6	11000 (4990)
	187 (4760)	98.4 (2500)	220.1 (5590)	232.3 (5900)	63.4 (1610)	51.2 (1300)	5	6	10957 (4970)
	199 (5060)	103.5 (2630)	231.9 (5890)	244.1 (6200)	68.5 (1740)	56.3 (1430)	5	6	10780 (4890)
Full Free-Lift 3-Stage, 4-Cylinder (FSW)	219 (5560)	113.4 (2880)	251.6 (6390)	263.8 (6700)	78.3 (1990)	66.1 (1680)	5	6	10471 (4750)
	238.5 (6060)	123.2 (3130)	271.3 (6890)	283.5 (7200)	88.2 (2240)	76 (1930)	5	6	10163 (4610)
	258 (6560)	133.1 (3380)	290.9 (7390)	303.1 (7700)	98 (2490)	85.8 (2180)	5	6	8488 (3850)
	171.5 (4360)	92.9 (2360)	204.3 (5190)	216.5 (5500)	57.9 (1470)	45.7 (1160)	5	6	11000 (4990)
	187 (4760)	98.4 (2500)	220.1 (5590)	232.3 (5900)	63.4 (1610)	51.2 (1300)	5	6	10957 (4970)
	199 (5060)	103.5 (2630)	231.9 (5890)	244.1 (6200)	68.5 (1740)	56.3 (1430)	5	6	10780 (4890)

MAST TYPE	MAXIMUM FORK HEIGHT (TOP OF FORKS)	OVERALL HEIGHT		FREE LIFT	TILT RANGE		LOAD CAPACITY AT
		LOWERED	EXTENDED		FWD	BWD	24 IN. (610 MM) LOAD CENTER*
		in (mm)	in (mm)	in (mm)			
9FBM60T							
Wide Visible (V)	132 (3360)	103.1 (2620)	167.4 (4252)	3.9 (100)	5	5	13230 (6000)
	148 (3760)	111 (2820)	183.2 (4652)	3.9 (100)	5	5	13230 (6000)
	160 (4060)	118.9 (3020)	195.7 (4970)	3.9 (100)	5	5	13230 (6000)
	179.5 (4560)	128.7 (3270)	215.4 (5470)	3.9 (100)	5	5	13230 (6000)
	199 (5060)	138.6 (3520)	235 (5970)	3.9 (100)	5	5	13230 (6000)
	219 (5560)	148.5 (3770)	254.7 (6470)	3.9 (100)	5	5	13230 (6000)
Full Free-Lift 2-Stage (FV)	238.5 (6060)	158.3 (4020)	274.4 (6970)	3.9 (100)	5	5	13230 (6000)
	132 (3360)	103.1 (2620)	168.5 (4280)	67.1 (1705)	5	5	13230 (6000)
	148 (3760)	111 (2820)	184.3 (4680)	75 (1905)	5	5	13230 (6000)
Full Free-Lift 3-Stage (FSV)	160 (4060)	118.9 (3020)	196.1 (4980)	80.9 (2055)	5	5	13230 (6000)
	171.5 (4360)	103.1 (2620)	207.9 (5280)	65.2 (1655)	5	5	13230 (6000)
	187.5 (4760)	107.1 (2720)	223.6 (5680)	69.1 (1755)	5	5	13230 (6000)
	199 (5060)	111 (2820)	235.4 (5980)	73 (1855)	5	5	13230 (6000)
	219 (5560)	118.9 (3020)	255.1 (6480)	80.9 (2055)	5	5	13230 (6000)
	238.5 (6060)	126.8 (3220)	274.8 (6980)	88.8 (2255)	5	5	13230 (6000)
Full Free-Lift 3-Stage, 4-Cylinder (FSW)	258 (6560)	134.6 (3420)	294.5 (7480)	96.7 (2455)	5	5	13230 (6000)
	278 (7060)	142.5 (3620)	314.2 (7980)	104.5 (2655)	5	5	13230 (6000)

¹ Height of standard load backrest is 48" (1220 mm)
 * All capacities of 1,500 lbs or less are subject to a secondary review and could be denied by Toyota

MAST TYPE	MAXIMUM FORK HEIGHT (TOP OF FORKS)	OVERALL HEIGHT		FREE LIFT	TILT RANGE		LOAD CAPACITY AT
		LOWERED	EXTENDED		FWD	BWD	24 IN. (610 MM) LOAD CENTER*
							in (mm)
9FBM70T							
Wide Visible (V)	132 (3360)	107.1 (2720)	171.3 (4352)	3.9 (100)	5	8	15430 (7000)
	148 (3760)	115 (2920)	187.1 (4752)	3.9 (100)	5	8	15430 (7000)
	160 (4060)	122.8 (3120)	199.5 (5070)	3.9 (100)	5	8	15430 (7000)
	179.5 (4560)	132.5 (3370)	219.5 (5570)	3.9 (100)	5	8	15430 (7000)
	199 (5060)	142.5 (3620)	239 (6070)	3.9 (100)	5	8	15430 (7000)
	219 (5560)	152.4 (3870)	258.5 (6570)	3.9 (100)	5	8	15430 (7000)
Full Free-Lift 2-Stage (FV)	238.5 (6060)	162.2 (4120)	278.5 (7070)	3.9 (100)	5	8	15430 (7000)
	132 (3360)	107.1 (2720)	168.5 (4280)	68.5 (1740)	5	8	15430 (7000)
	148 (3760)	115 (2920)	184.3 (4680)	76.4 (1940)	5	8	15430 (7000)
Full Free-Lift 3-Stage (FSV)	160 (4060)	122.8 (3120)	196.1 (4980)	84.3 (2140)	5	8	15430 (7000)
	171.5 (4360)	103.1 (2620)	207.9 (5280)	65.2 (1655)	5	8	15430 (7000)
	187.5 (4760)	107.1 (2720)	223.6 (5680)	69.1 (1755)	5	8	15430 (7000)
	199 (5060)	111 (2820)	235.4 (5980)	73 (1855)	5	8	15430 (7000)
	219 (5560)	118.9 (3020)	255.1 (6480)	80.9 (2055)	5	8	14770 (6700)
	238.5 (6060)	126.8 (3220)	274.8 (6980)	88.8 (2255)	5	8	14770 (6700)
	258 (6560)	134.6 (3420)	294.5 (7480)	96.7 (2455)	5	8	13670 (6200)
278 (7060)	142.5 (3620)	314.2 (7980)	104.5 (2655)	5	8	13670 (6200)	

MAST TYPE	MAXIMUM FORK HEIGHT (TOP OF FORKS)	OVERALL HEIGHT		FREE LIFT	TILT RANGE		LOAD CAPACITY AT
		LOWERED	EXTENDED		FWD	BWD	24 IN. (610 MM) LOAD CENTER*
							in (mm)
9FBM80T							
Wide Visible (V)	132 (3360)	103.1 (2620)	167.5 (4255)	3.9 (100)	5	8	17640 (8000)
	148 (3760)	115 (2920)	185.8 (4720)	3.9 (100)	5	8	17640 (8000)
	160 (4060)	122.8 (3120)	199.5 (5070)	3.9 (100)	5	8	17640 (8000)
	179.5 (4560)	132.5 (3370)	219.5 (5570)	3.9 (100)	5	8	17640 (8000)
	199 (5060)	142.5 (3620)	239 (6070)	3.9 (100)	5	8	17640 (8000)
	219 (5560)	152.4 (3870)	258.5 (6570)	3.9 (100)	5	8	17640 (8000)
Full Free-Lift 2-Stage (FV)	238.5 (6060)	162.2 (4120)	278.5 (7070)	3.9 (100)	5	8	16975 (7700)
	132 (3360)	105.1 (2670)	170.6 (4334)	67.1 (1705)	5	8	17640 (8000)
	148 (3760)	115 (2920)	186.4 (4734)	77 (1955)	5	8	17640 (8000)
Full Free-Lift 3-Stage (FSV)	160 (4060)	122.8 (3120)	198.2 (5034)	84.8 (2155)	5	8	17640 (8000)
	171.5 (4360)	105.9 (2690)	210.7 (5353)	67.3 (1710)	5	8	17640 (8000)
	187.5 (4760)	111 (2820)	226.5 (5753)	72.4 (1840)	5	8	17640 (8000)
	199 (5060)	115 (2920)	238.3 (6053)	76.4 (1940)	5	8	17640 (8000)
	219 (5560)	121.7 (3090)	258 (6553)	83.1 (2110)	5	8	17640 (8000)
	238.5 (6060)	128.3 (3260)	277.7 (7053)	89.8 (2280)	5	8	16975 (7700)
	258 (6560)	135 (3430)	297.4 (7553)	96.5 (2450)	5	8	16535 (7500)
278 (7060)	142.5 (3620)	317 (8053)	104 (2640)	5	8	16535 (7500)	

MAST TYPE	MAXIMUM FORK HEIGHT (TOP OF FORKS)	OVERALL HEIGHT		FREE LIFT	TILT RANGE		LOAD CAPACITY AT
		LOWERED	EXTENDED		FWD	BWD	24 IN. (610 MM) LOAD CENTER*
							in (mm)
9FBH80T							
Wide Visible (V)	132.5 (3370)	111 (2820)	176.4 (4480)	3.93 (100)	5	8	17640 (8000)
	148.5 (3770)	122.8 (3120)	193.7 (4920)	3.93 (100)	5	8	17640 (8000)
	160.5 (4070)	130.7 (3320)	207.5 (5270)	3.93 (100)	5	8	17640 (8000)
	180 (4570)	140.5 (3570)	227.2 (5770)	3.93 (100)	5	8	17640 (8000)
	199.5 (5070)	150.4 (3820)	246.9 (6270)	3.93 (100)	5	8	16975 (7700)
	219.5 (5570)	160.5 (4070)	266.5 (6770)	3.93 (100)	5	8	16975 (7700)
	239 (6070)	170.1 (4320)	286.2 (7270)	3.93 (100)	5	8	16535 (7500)
Full Free-Lift 2-Stage (FV)	132.5 (3370)	109.1 (2770)	170.6 (4334)	68.7 (1745)	5	8	17640 (8000)
	148.5 (3770)	118.9 (3020)	186.4 (4734)	78.5 (1995)	5	8	17640 (8000)
	160.5 (4070)	126.8 (3220)	198.2 (5034)	86.4 (2195)	5	8	17640 (8000)
Full Free-Lift 3-Stage (FSV)	172 (4370)	111 (2820)	219.5 (5575)	60.8 (1545)	5	8	17640 (8000)
	188 (4770)	116.1 (2950)	235.2 (5975)	65 (1675)	5	8	17640 (8000)
	199.5 (5070)	120.1 (3050)	247.1 (6275)	69.9 (1775)	5	8	17640 (8000)
	219.5 (5570)	126.8 (3220)	266.7 (6775)	76.6 (1945)	5	8	17640 (8000)
	239 (6070)	133.5 (3390)	286.4 (7275)	83.3 (2115)	5	8	16975 (7700)
	258.5 (6570)	139.8 (3550)	306.1 (7775)	89.6 (2275)	5	8	16094 (7300)
278.5 (7070)	146.5 (3720)	325.8 (8275)	96.3 (2445)	5	8	16094 (7300)	

1 Height of standard load backrest is 48" (1220 mm)
* All capacities of 1,500 lbs or less are subject to a secondary review and could be denied by Toyota



“ I’M HERE TO MAKE SURE YOUR FORKLIFTS DON’T TAKE VACATION DAYS.”

Butch - 360 Technician, ProLift, Cincinnati, Ohio



HELP IS ALWAYS HERE WITH TOYOTA 360 SUPPORT.
The industry’s best and most comprehensive dealer network quickly delivers Toyota Certified Technicians to your work site. These specially trained technicians can also help assess your warehouse and facility needs to recommend the right equipment for the job. And with the largest fleet of material handling equipment, Toyota 360 keeps your business running at full speed.

ToyotaForklift.com/360-Support



YOUR BUSINESS IS RIDING ON IT.

Some product features described herein are optional. Please consult your dealer for specifications. Details of specifications and equipment are based on information available at time of printing and may change without notice. Photos may not reflect physical trucks.

