

# CORE IC PNEUMATIC



3000 - 6500 LBS.

SPECIFICATIONS



50-8FGU15-32 | 40-8FGU15-32

CLASS  
5

INTERNAL COMBUSTION ENGINE PNEUMATIC TIRE

[ToyotaForklift.com](http://ToyotaForklift.com)

## CORE IC PNEUMATIC

CAPACITY  
**3000 - 6500 LBS.**

WHEELBASE  
**58.5 - 66.9 IN.**

LOAD CENTER  
**24 IN.**

### INDUSTRIES



Brick, Block  
& Pipe



Distribution



Factory



General  
Manufacturing



General  
Warehousing



Lumber



Paper



Retail

## STANDARD FEATURES

### DURABILITY

- Control Area Network (CAN-bus) communication
- Limited free-lift 2-stage mast (V)
- Fully stamped steel side panels
- Moisture-resistant electric connectors
- Tilt cylinder boots

- High cooling capacity radiator with fan shroud
- Low-maintenance battery
- Large-capacity engine-cooling fan
- 7" cyclone air cleaner with high positioned external air intake
- Plate-iron front fenders

- Anti-restart ignition key switch
- Stamped steel engine hood
- Fully sealed air intake system
- Self-adjusting brakes
- Rear wheel well covers
- Scratch zones on both sides of counterweight

### SUPPORT

- System of Active Stability™ (SAS)
- Operator Presence Sensing System (OPSS)
- Speed control
- Bolt-on overhead guard

- Key lowering interlock
- High-durability electric horn
- LED headlights
- Neutral start safety switch
- Asbestos-free components

- Single touch maximum speed limitation & low speed setting
- Key off/headlight off system

### PERFORMANCE

- UL "LP" engine<sup>1</sup>
  - 4Y-US 136 cu. in., 4-cylinder engine
  - OHV EPA/CARB certified LP engine
  - 3-way catalytic muffler system
- Dual fuel engine<sup>1</sup>
  - Kubota WG2503 4-cylinder engine
  - OHV EPA/CARB certified engine - G/LP or LPG
  - Single type muffler/ 3-way catalyst
- Distributor less ignition (DLI)
- Alternator with built-in regulator

- Automatic transmission with oil cooler
- Full-floating powertrain
- Fuel system configurations with swing-out tank bracket & one-touch latch system
- Electric shift control
- LCD multi-function display – includes:
  - Data log, fuel, and operation information with QR code output
  - Various hours meters
- Engine coolant temperature gauge

- Fuel gauge (excluding LP)
- Check engine light
- Engine oil pressure warning light
- OPSS activation light
- Parking brake indicator
- SAS/OPSS warning light
- Master warning, wheel, direction, and mast tilt indicators

### ERGONOMICS/CABIN

- Dash-mounted instrument display
- 11.8"-dia., two-spoke steering wheel
- Load-sensing hydrostatic power steering
- Heavy-duty non-slip rubber floor mat
- 12"-long dual operator assist grips
- One-way automatic fork leveling

- Integrated headlight & turn signal lever
- Cowl-mounted hydraulic control levers with rubber boot covers
- Low, wide-entry steps
- Orange, non-cinching seatbelt
- Independent brake & inching pedals

- Oversized cup holder
- Premium Seat with full-suspension
- Slim profile, tilt steering column
- Foot-activated parking brake

### SERVICEABILITY

- Easy-access, no tools required floorboard
- Engine hood assist damper with lock device

- Air cleaner discharge valve
- Externally-mounted hydraulic oil return filter

- Dash-mounted brake fluid level check
- Easy-lift engine hood with wide 75° opening

<sup>1</sup> - Engine type dictated by fuel option chosen

## OPTIONAL EQUIPMENT

- Travel speed/acceleration control system
- Hydraulic accumulator
- Intelli-Shift
- Rear assist grip with horn button
- Rustproof spec
- Mini-lever controls with ErgoShift
- EZ Control Joystick®
- EZ Fingertip Controls®
- Swivel seat
- Synchronized steering
- LED front combination lights
- LED rear combination lights
- Deluxe steel cab
- Standard steel cab
- 12-Volt power supply
- EZ Pedal (foot directional control)
- Plate fin radiator
- Radiator screen
- Fire extinguisher
- Steering wheel with knob
- Polished and tapered forks
- Integral & hang-on sidershifters
- Integral side shifting fork positioner
- Bottler's tilt
- LPG low-fuel warning light & alarm
- High-capacity 80-amp alternator (4Y-US models)
- Strobe lights
- Step-mounted toolbox with cover
- Cloth 4-way adjustable full-suspension seat
- Back up alarms
- Combination brake & inching pedal
- Pre-cleaner for air intake
- Rearview mirrors
- Wide tread tires
- UL LP, G/LP, and LPS models available
- Swing-down LPG tank bracket
- Reverse-activated blue light
- Seatbelt interlock

Please contact your local, authorized Toyota Dealer for a complete list of available options.



# TRUCK SPECIFICATIONS

MODEL NUMBERS

GENERAL DATA			40-8FGU15	50-8FGU15	40-8FGU18	50-8FGU18			
Load Capacity	lb (kg)		3000 (1350)	3000 (1350)	3500 (1600)	3500 (1600)			
Power Type			Gasoline/LP	LP	Gasoline/LP	LP			
Operator Position			Seated Rider	Seated Rider	Seated Rider	Seated Rider			
Tire Type	Front / Rear	Pneumatic / Pneumatic		Pneumatic / Pneumatic	Pneumatic / Pneumatic	Pneumatic / Pneumatic			
Wheels (x = driven)	Front / Rear	2x / 2		2x / 2	2x / 2	2x / 2			
EXTERIOR DIMENSIONS			40-8FGU15	50-8FGU15	40-8FGU18	50-8FGU18			
<b>A</b> Maximum Fork Height (top of forks)	in (mm)	131 (3335)		131 (3335)	131 (3335)	131 (3335)			
<b>B</b> Free-Lift (top of forks)	in (mm)	5.7 (145)		5.7 (145)	5.7 (145)	5.7 (145)			
<b>C</b> Fork Size (T x W x L)	in (mm)	1.4 x 4 x 42 (35 x 100 x 1070)		1.4 x 4 x 42 (35 x 100 x 1070)	1.4 x 4 x 42 (35 x 100 x 1070)	1.4 x 4 x 42 (35 x 100 x 1070)			
<b>D</b> Fork Spread Max. / Min. (outer edge to edge)	in (mm)	36 (920) / 8 (200)		36 (920) / 8 (200)	36 (920) / 8 (200)	36 (920) / 8 (200)			
<b>E</b> Tilt Range (forward / backward)	deg	6 / 11		6 / 11	6 / 11	6 / 11			
<b>F</b> Length to Fork Face	in (mm)	89.6 (2275)		89.6 (2275)	90.7 (2305)	90.7 (2305)			
<b>G</b> Overall Width	in (mm)	42.1 (1070)		42.1 (1070)	42.1 (1070)	42.1 (1070)			
<b>H</b> Mast Lowered Height	in (mm)	84.5 (2145)		84.5 (2145)	84.5 (2145)	84.5 (2145)			
<b>I</b> Mast Extended Height (top of load backrest)	in (mm)	179.3 (4555)		179.3 (4555)	179.3 (4555)	179.3 (4555)			
<b>J</b> Overhead Guard Height	in (mm)	81.9 (2080)		81.9 (2080)	81.9 (2080)	81.9 (2080)			
<b>K</b> Turning Radius (inside / outside)	in (mm)	1.38 (35) / 76 (1930)		1.38 (35) / 76 (1930)	1.38 (35) / 78 (1980)	1.38 (35) / 78 (1980)			
<b>L</b> Load Distance <sup>1</sup>	in (mm)	15.9 (405)		15.9 (405)	15.9 (405)	15.9 (405)			
<b>M</b> Rear Overhang	in (mm)	15.2 (385)		15.2 (385)	16.3 (415)	16.3 (415)			
<b>N</b> Basic Right-Angle Stacking Aisle Width <sup>2</sup>	in (mm)	91.9 (2335)		91.9 (2335)	93.9 (2385)	93.9 (2385)			
PERFORMANCE DATA			40-8FGU15	50-8FGU15	40-8FGU18	50-8FGU18			
Speeds	Maximum Travel (forward / reverse)	Full Load	mph (km/h)	11.5 (18.5) / 11.5 (18.5)	11.5 (18.5) / 11.5 (18.5)	11.5 (18.5) / 11.5 (18.5)	11.5 (18.5) / 11.5 (18.5)		
		No Load	mph (km/h)	11.8 (19.0) / 11.8 (19.0)	11.8 (19.0) / 11.8 (19.0)	11.8 (19.0) / 11.8 (19.0)	11.8 (19.0) / 11.8 (19.0)		
	Lifting	Full Load	fpm (mm/sec)	131 (665)	131 (665)	131 (665)	131 (665)		
		No Load	fpm (mm/sec)	134 (680)	134 (680)	134 (680)	134 (680)		
	Lowering	Full Load	fpm (mm/sec)	98 (500)	98 (500)	98 (500)	98 (500)		
		No Load	fpm (mm/sec)	108 (550)	108 (550)	108 (550)	108 (550)		
Drawbar Pull	Maximum	Full Load	lb (kg)	3940 (1790) / 4170 (1890)	4170 (1890)	3940 (1790) / 4170 (1890)	4170 (1890)		
	No Load	lb (kg)	1550 (700)	1550 (700)	1300 (590)	1300 (590)			
Gradeability	1 mph (1.5 km/h) <sup>3</sup>	Full Load	%	41/43	43	36/38	38		
		Maximum <sup>3</sup>	Full Load	%	45	45	45	45	
			No Load	%	22	22	20	20	
TRUCK WEIGHTS			40-8FGU15	50-8FGU15	40-8FGU18	50-8FGU18			
Total Weight	lb (kg)		5670 (2570)	5500 (2500)	6090 (2760)	5920 (2690)			
Weight Distribution	Full Load (front / rear)	lb (kg)	7620 (3580) / 1050 (490)	7560 (3560) / 940 (440)	8460 (3980) / 1130 (530)	8400 (3960) / 1020 (480)			
	No Load (front / rear)	lb (kg)	2560 (1160) / 3110 (1410)	2500 (1140) / 3000 (1360)	2560 (1160) / 3530 (1600)	2500 (1140) / 3420 (1550)			
TIRES			40-8FGU15	50-8FGU15	40-8FGU18	50-8FGU18			
Tires	Number (front / rear)		2 / 2		2 / 2		2 / 2		
	Size	Front	6.50-10-10PR (1)		6.50-10-10PR (1)		6.50-10-10PR (1)		
		Rear	5.00-8-8PR (1)		5.00-8-8PR (1)		5.00-8-8PR (1)		
Wheelbase	in (mm)		58.5 (1485)		58.5 (1485)		58.5 (1485)		
Tread Width (front / rear)	in (mm)		34.8 (885) / 35.2 (895)		34.8 (885) / 35.2 (895)		34.8 (885) / 35.2 (895)		
Underclearance (full load)	Minimum with Load	in (mm)		3.9 (100)		3.9 (100)		3.9 (100)	
	Center of Wheelbase	in (mm)		4.5 (115)		4.5 (115)		4.5 (115)	
Brake	Service (foot) / Parking		Hydraulic / Mechanical		Hydraulic / Mechanical		Hydraulic / Mechanical		
POWER SYSTEM			40-8FGU15	50-8FGU15	40-8FGU18	50-8FGU18			
Battery (5-hour rating)	V / Ah		12/35		12/35		12 / 35		
Internal Combustion Engine	Make / Model		Kubota/WG2503		4Y - US		Kubota/WG2503		
	Rated Horsepower @ rpm	SAE HP	56 @ 2600 Net/ 58 @ 2600 Net		51 @ 2570 Net		56 @ 2600 Net/ 58 @ 2600 Net		
		(kW)	42 @ 2600 / 44 @ 2600		(38 @ 2570)		42 @ 2600/44 @ 2600		
	Rated Torque @ rpm	SAE ft-lb	122 @ 1800 Net/129 @ 1600 Net		112 @ 1800 Net		122 @ 1800 Net/ 129 @ 1600 Net		
		(N-m)	165 @ 1800/175 @ 1600		(152 @ 1800)		165 @ 1800/175 @ 1600		
	Number of Cylinders			4		4		4	
Piston Displacement	cu in (cc)		151(2491)		136 (2237)		151(2491)		
Fuel Tank Capacity	US gal (liter)		12 (45)		12 (45)		12 (45)		
Transmission	Type		Powershift		Powershift		Powershift		
	Speeds (forward / reverse)		1/1		1/1		1/1		
Auxiliary Hydraulic Function Specifications (for attachments) <sup>4</sup>	Max. Operating Pressure	psi (kg/cm <sup>2</sup> )		2275 (160)		2275 (160)			
	Max. Flow Rate	gpm		17		17			

1 Load distance at centerline of front axle to front face of forks.  
 2 Basic right-angle stacking aisle width, add load length & clearance.

3 Computed values. Performance of LPG fuel system may be less than that of standard model shown.  
 4 Values taken at Hydraulic Control Valve. Does not take in to consideration losses through mast plumbing (hosing, fittings, QDs, etc.).

MODEL NUMBERS

GENERAL DATA				40-8FGU20	50-8FGU20	40-8FGU25	50-8FGU25	
Load Capacity	lb (kg)			4000 (1800)	4000 (1800)	5000 (2250)	5000 (2250)	
Power Type				Gasoline/LP	LP	Gasoline/LP	LP	
Operator Position				Seated Rider	Seated Rider	Seated Rider	Seated Rider	
Tire Type	Front / Rear	Pneumatic / Pneumatic			Pneumatic / Pneumatic	Pneumatic / Pneumatic	Pneumatic / Pneumatic	
Wheels (x = driven)	Front / Rear	2x / 2			2x / 2	2x / 2	2x / 2	
EXTERIOR DIMENSIONS				40-8FGU20	50-8FGU20	40-8FGU25	50-8FGU25	
<b>A</b> Maximum Fork Height (top of forks)	in (mm)	131.5 (3340)			131.5 (3340)	131.5 (3340)	131.5 (3340)	
<b>B</b> Free-Lift (top of forks)	in (mm)	6.1 (155)			6.1 (155)	6.1 (155)	6.1 (155)	
<b>C</b> Fork Size (T x W x L)	in (mm)	1.6 x 5 x 42 (40 x 125 x 1070)			1.6 x 5 x 42 (40 x 125 x 1070)	1.6 x 5 x 42 (40 x 125 x 1070)	1.6 x 5 x 42 (40 x 125 x 1070)	
<b>D</b> Fork Spread Max. / Min. (outer edge to edge)	in (mm)	40 (1020) / 10 (250)			40 (1020) / 10 (250)	40 (1020) / 10 (250)	40 (1020) / 10 (250)	
<b>E</b> Tilt Range (forward / backward)	deg	6 / 11			6 / 11	6 / 11	6 / 11	
<b>F</b> Length to Fork Face	in (mm)	101.4 (2575)			101.4 (2575)	103.9 (2640)	103.9 (2640)	
<b>G</b> Overall Width	in (mm)	45.3 (1150)			45.3 (1150)	45.3 (1150)	45.3 (1150)	
<b>H</b> Mast Lowered Height	in (mm)	84.5 (2145)			84.5 (2145)	84.5 (2145)	84.5 (2145)	
<b>I</b> Mast Extended Height (top of load backrest)	in (mm)	179.5 (4560)			179.5 (4560)	179.5 (4560)	179.5 (4560)	
<b>J</b> Overhead Guard Height	in (mm)	83.1 (2110)			83.1 (2110)	83.1 (2110)	83.1 (2110)	
<b>K</b> Turning Radius (inside / outside)	in (mm)	5.91 (150) / 84.7 (2150)			5.91 (150) / 84.7 (2150)	5.91 (150) / 87.5 (2220)	5.91 (150) / 87.5 (2220)	
<b>L</b> Load Distance <sup>1</sup>	in (mm)	18.5 (470)			18.5 (470)	18.5 (470)	18.5 (470)	
<b>M</b> Rear Overhang	in (mm)	17.9 (455)			17.9 (455)	20.5 (520)	20.5 (520)	
<b>N</b> Basic Right-Angle Stacking Aisle Width <sup>2</sup>	in (mm)	103.2 (2620)			103.2 (2620)	105.9 (2690)	105.9 (2690)	
PERFORMANCE DATA				40-8FGU20	50-8FGU20	40-8FGU25	50-8FGU25	
Speeds	Maximum Travel (forward / reverse)	Full Load	mph (km/h)	10.9 (17.5) / 10.9 (17.5)	10.9 (17.5) / 10.9 (17.5)	10.9 (17.5) / 10.9 (17.5)	10.9 (17.5) / 10.9 (17.5)	
		No Load	mph (km/h)	11.2 (18.0) / 11.2 (18.0)	11.2 (18.0) / 11.2 (18.0)	11.2 (18.0) / 11.2 (18.0)	11.2 (18.0) / 11.2 (18.0)	
	Lifting	Full Load	fpm (mm/sec)	118 (600)	118 (600)	118 (600)	118 (600)	
		No Load	fpm (mm/sec)	124 (630)	126 (640)	124 (630)	126 (640)	
	Lowering	Full Load	fpm (mm/sec)	98 (500)	98 (500)	98 (500)	98 (500)	
		No Load	fpm (mm/sec)	98 (500)	98 (500)	98 (500)	98 (500)	
Drawbar Pull	Maximum	Full Load	lb (kg)	4160 (1890)/4250 (1930)	4250 (1928)	4160 (1890)/4250 (1930)	4250 (1928)	
		No Load	lb (kg)	2020 (915)	2020 (915)	1910 (870)	1910 (870)	
Gradeability	1 mph (1.5 km/h) <sup>3</sup>	Full Load	%	31/33	33	26/28	28	
		Maximum <sup>3</sup>	Full Load	%	37/39	39	31/33	33
			No Load	%	23	23	20	20
TRUCK WEIGHTS				40-8FGU20	50-8FGU20	40-8FGU25	50-8FGU25	
Total Weight	lb (kg)			7240(3280)	7080 (3210)	8000(3640)	7840 (3560)	
Weight Distribution	Full Load (front / rear)	lb (kg)			9820(4630) / 1420(650)	9750 (4600) / 1330 (610)	11340(5360)/1670(770)	11260 (5330) / 1580 (730)
	No Load (front / rear)	lb (kg)			3200 (1450) / 4040 (1830)	3130 (1420) / 3950 (1790)	3050(1380)/4950(2250)	2980 (1350) / 4860 (2210)
TIRES				40-8FGU20	50-8FGU20	40-8FGU25	50-8FGU25	
Tires	Number (front / rear)			2 / 2	2 / 2	2 / 2	2 / 2	
	Size	Front	7.00-12-12PR (1)			7.00-12-12PR (1)	7.00-12-12PR (1)	7.00-12-12PR (1)
		Rear	6.00-9-10PR (1)			6.00-9-10PR (1)	6.00-9-10PR (1)	6.00-9-10PR (1)
Wheelbase	in (mm)			65 (1650)	65 (1650)	65 (1650)	65 (1650)	
Tread Width (front / rear)	in (mm)			37.8 (960) / 38.0 (965)	37.8 (960) / 38.0 (965)	37.8 (960) / 38.0 (965)	37.8 (960) / 38.0 (965)	
Underclearance (full load)	Minimum with Load	in (mm)			3.7 (95)	3.7 (95)	3.7 (95)	3.7 (95)
	Center of Wheelbase	in (mm)			5.5 (140)	5.5 (140)	5.5 (140)	5.5 (140)
Brake	Service (foot) / Parking			Hydraulic / Mechanical	Hydraulic / Mechanical	Hydraulic / Mechanical	Hydraulic / Mechanical	
POWER SYSTEM				40-8FGU20	50-8FGU20	40-8FGU25	50-8FGU25	
Battery (5-hour rating)	V / Ah			12 / 35	12 / 35	12 / 35	12 / 35	
Internal Combustion Engine	Make / Model			Kubota/WG2503		4Y - US		
	Rated Horsepower @ rpm	SAE HP	56 @ 2600 Net/ 58 @ 2600 Net			51 @ 2570 Net	56 @ 2600 Net/ 58 @ 2600 Net	
		(kW)	42 @ 2600/ 44 @ 2600			(38 @ 2570)	42 @ 2600/ 44 @ 2600	
	Rated Torque @ rpm	SAE ft-lb	122 @ 1800 Net/ 129 @ 1600 Net			112 @ 1800 Net	122 @ 1800 Net/ 129 @ 1600 Net	
		(N-m)	165 @ 1800 / 175 @ 1600			(152 @ 1800)	165 @ 1800 / 175 @ 1600	
	Number of Cylinders	4			4	4		
Piston Displacement	cu in (cc)	151(2491)			136 (2237)	151(2491)		
Fuel Tank Capacity	US gal (liter)			15.9	15.9	15.9		
Transmission	Type			Powershift		Powershift		
	Speeds (forward / reverse)			1 / 1		1 / 1		
Auxiliary Hydraulic Function Specifications (for attachments) <sup>4</sup>	Max. Operating Pressure	psi (kg/cm <sup>2</sup> )			2275 (160)	2275 (160)	2275 (160)	
	Max. Flow Rate	gpm			20	20	20	

1 Load distance at centerline of front axle to front face of forks.

2 Basic right-angle stacking aisle width, add load length & clearance.

3 Computed values. Performance of LPG fuel system may be less than that of standard model shown.

4 Values taken at Hydraulic Control Valve. Does not take in to consideration losses through mast plumbing (hosing, fittings, QDs, etc.).

5 LPG-only units.

# TRUCK SPECIFICATIONS

MODEL NUMBERS

GENERAL DATA			40-8FGU30	50-8FGU30	40-8FGU32	50-8FGU32	
Load Capacity	lb (kg)		6000 (2700)	6000 (2700)	6500 (3000)	6500 (3000)	
Power Type			Gasoline/LP	LP	Gasoline/LP	LP	
Operator Position			Seated Rider	Seated Rider	Seated Rider	Seated Rider	
Tire Type	Front / Rear		Pneumatic / Pneumatic	Pneumatic / Pneumatic	Pneumatic / Pneumatic	Pneumatic / Pneumatic	
Wheels (x = driven)	Front / Rear		2x / 2	2x / 2	2x / 2	2x / 2	
EXTERIOR DIMENSIONS			40-8FGU30	50-8FGU30	40-8FGU32	50-8FGU32	
<b>A</b> Maximum Fork Height (top of forks)	in (mm)		131.5 (3345)	131.5 (3345)	131.5 (3345)	131.5 (3345)	
<b>B</b> Free-Lift (top of forks)	in (mm)		5.3 (135)	5.3 (135)	5.3 (135)	5.3 (135)	
<b>C</b> Fork Size (T x W x L)	in (mm)		1.8 x 5 x 42 (45 x 125 x 1070)	1.8 x 5 x 42 (45 x 125 x 1070)	1.8 x 5 x 42 (45 x 125 x 1070)	1.8 x 5 x 42 (45 x 125 x 1070)	
<b>D</b> Fork Spread Max. / Min. (outer edge to edge)	in (mm)		42 (1070) / 10 (250)	42 (1070) / 10 (250)	42 (1070) / 10 (250)	42 (1070) / 10 (250)	
<b>E</b> Tilt Range (forward / backward)	deg		6 / 11	6 / 11	6 / 11	6 / 11	
<b>F</b> Length to Fork Face	in (mm)		109.4 (2780)	109.4 (2780)	110.2 (2800)	110.2 (2800)	
<b>G</b> Overall Width	in (mm)		48.8 (1240)	48.8 (1240)	48.8 (1240)	48.8 (1240)	
<b>H</b> Mast Lowered Height	in (mm)		85.3 (2165)	85.3 (2165)	85.3 (2165)	85.3 (2165)	
<b>I</b> Mast Extended Height (top of load backrest)	in (mm)		179.7 (4565)	179.7 (4565)	179.7 (4565)	179.7 (4565)	
<b>J</b> Overhead Guard Height	in (mm)		85.5 (2170)	85.5 (2170)	85.5 (2170)	85.5 (2170)	
<b>K</b> Turning Radius (inside / outside)	in (mm)		7.48 (190) / 92.5 (2350)	7.48 (190) / 92.5 (2350)	93.3 (2370)	93.3 (2370)	
<b>L</b> Load Distance <sup>1</sup>	in (mm)		19.1 (485)	19.1 (485)	19.1 (485)	19.1 (485)	
<b>M</b> Rear Overhang	in (mm)		23 (595)	23 (595)	24 (615)	24 (615)	
<b>N</b> Basic Right-Angle Stacking Aisle Width <sup>2</sup>	in (mm)		111.6 (2835)	111.6 (2835)	112.4 (2855)	112.4 (2855)	
PERFORMANCE DATA			40-8FGU30	50-8FGU30	40-8FGU32	50-8FGU32	
Speeds	Maximum Travel (forward / reverse)	Full Load	mph (km/h)	11.2 (18.0) / 11.2 (18.0)	11.2 (18.0) / 11.2 (18.0)	11.2 (18.0) / 11.2 (18.0)	11.2 (18.0) / 11.2 (18.0)
		No Load	mph (km/h)	11.5 (18.5) / 11.5 (18.5)	11.5 (18.5) / 11.5 (18.5)	11.5 (18.5) / 11.5 (18.5)	11.5 (18.5) / 11.5 (18.5)
	Lifting	Full Load	fpm (mm/sec)	98(500)	100 (510)	98(500)	100 (510)
		No Load	fpm (mm/sec)	102(520)	108 (550)	102(520)	108 (550)
	Lowering	Full Load	fpm (mm/sec)	98 (500)	98 (500)	98 (500)	98 (500)
		No Load	fpm (mm/sec)	98 (500)	98 (500)	98 (500)	98 (500)
Drawbar Pull	Maximum	Full Load	lb (kg)	4280 (1940)/4390 (1990)	4040 (1830)	4280 (1940)/4390 (1990)	4040 (1830)
		No Load	lb (kg)	2310 (1050)	2310 (1050)	2310 (1050)	2310 (1050)
Gradeability	1 mph (1.5 km/h) <sup>3</sup>	Full Load	%	22/24	22	22/24	21
		Full Load	%	25/26	25	25/26	24
	Maximum <sup>3</sup>	No Load	%	21	21	21	21
TRUCK WEIGHTS			40-8FGU30	50-8FGU30	40-8FGU32	50-8FGU32	
Total Weight	lb (kg)		9450(4280)	9270 (4210)	9680(4390)	9500 (4320)	
Weight Distribution	Full Load (front / rear)	lb (kg)	13370(6330)/2080(950)	13290 (6300) / 1980 (910)	14130 (6700)/2050 (940)	14050 (6670) / 1950 (900)	
	No Load (front / rear)	lb (kg)	3510(1590)/5940(2690)	3430 (1560) / 5840 (2650)	3440(1560)/6240(2830)	3360 (1530) / 6140 (2790)	
TIRES			40-8FGU30	50-8FGU30	40-8FGU32	50-8FGU32	
Tires	Number (front / rear)		2 / 2	2 / 2	2 / 2	2 / 2	
	Size	Front	28 x 9-15-12PR (1)	28 x 9-15-12PR (1)	28 x 9-15-14PR (1)	28 x 9-15-14PR (1)	
		Rear	6.50-10-10PR (1)	6.50-10-10PR (1)	6.50-10-10PR (1)	6.50-10-10PR (1)	
Wheelbase	in (mm)		66.9 (1700)	66.9 (1700)	66.9 (1700)	66.9 (1700)	
Tread Width (front / rear)	in (mm)		39.8 (1010) / 38 (965)	39.8 (1010) / 38 (965)	39.8 (1010) / 38 (965)	39.8 (1010) / 38 (965)	
Underclearance (full load)	Minimum with Load	in (mm)	4.5 (115)	4.5 (115)	4.5 (115)	4.5 (115)	
	Center of Wheelbase	in (mm)	7.3 (185)	7.3 (185)	7.3 (185)	7.3 (185)	
Brake	Service (foot) / Parking		Hydraulic / Mechanical	Hydraulic / Mechanical	Hydraulic / Mechanical	Hydraulic / Mechanical	
POWER SYSTEM			40-8FGU30	50-8FGU30	40-8FGU32	50-8FGU32	
Battery (5-hour rating)	V / Ah		12 / 35	12 / 35	12 / 35	12 / 35	
Internal Combustion Engine	Make / Model		Kubota/WG2503		4Y - US		
	Rated Horsepower @ rpm	SAE HP	56 @ 2600 Net/58 @ 2600 Net	51 @ 2570 Net	56 @ 2600 Net/58 @ 2600 Net	51 @ 2570 Net	
		(kW)	42 @ 2600/ 44 @ 2600	(38 @ 2570)	42 @ 2600/ 44 @ 2600	(38 @ 2570)	
	Rated Torque @ rpm	SAE ft-lb	122 @ 1800 Net/ 129 @ 1600 Net	112 @ 1800 Net	122 @ 1800 Net/ 129 @ 1600 Net	112 @ 1800 Net	
		(N-m)	165 @ 1800/ 175 @ 1600	(152 @ 1800)	165 @ 1800/ 175 @ 1600	(152 @ 1800)	
	Number of Cylinders		4		4		
	Piston Displacement cu in (cc)		151(2491)		136 (2237)		
Fuel Tank Capacity US gal (liter)		15.9 (60)		15.9 (60)			
Transmission	Type		Powershift		Powershift		
	Speeds (forward / reverse)		1/1		1/1		
Auxiliary Hydraulic Function Specifications (for attachments) <sup>4</sup>	Max. Operating Pressure	psi (kg/cm <sup>2</sup> )	2275 (160)	2275 (160)	2275 (160)	2275 (160)	
	Max. Flow Rate	gpm	21	21	21	21	

1 Load distance at centerline of front axle to front face of forks.  
 2 Basic right-angle stacking aisle width, add load length & clearance.

3 Computed values. Performance of LPG fuel system may be less than that of standard model shown.  
 4 Values taken at Hydraulic Control Valve. Does not take in to consideration losses through mast plumbing (hosing, fittings, QDs, etc.).  
 5 LPG-only units.

# EXTERIOR DIMENSIONS

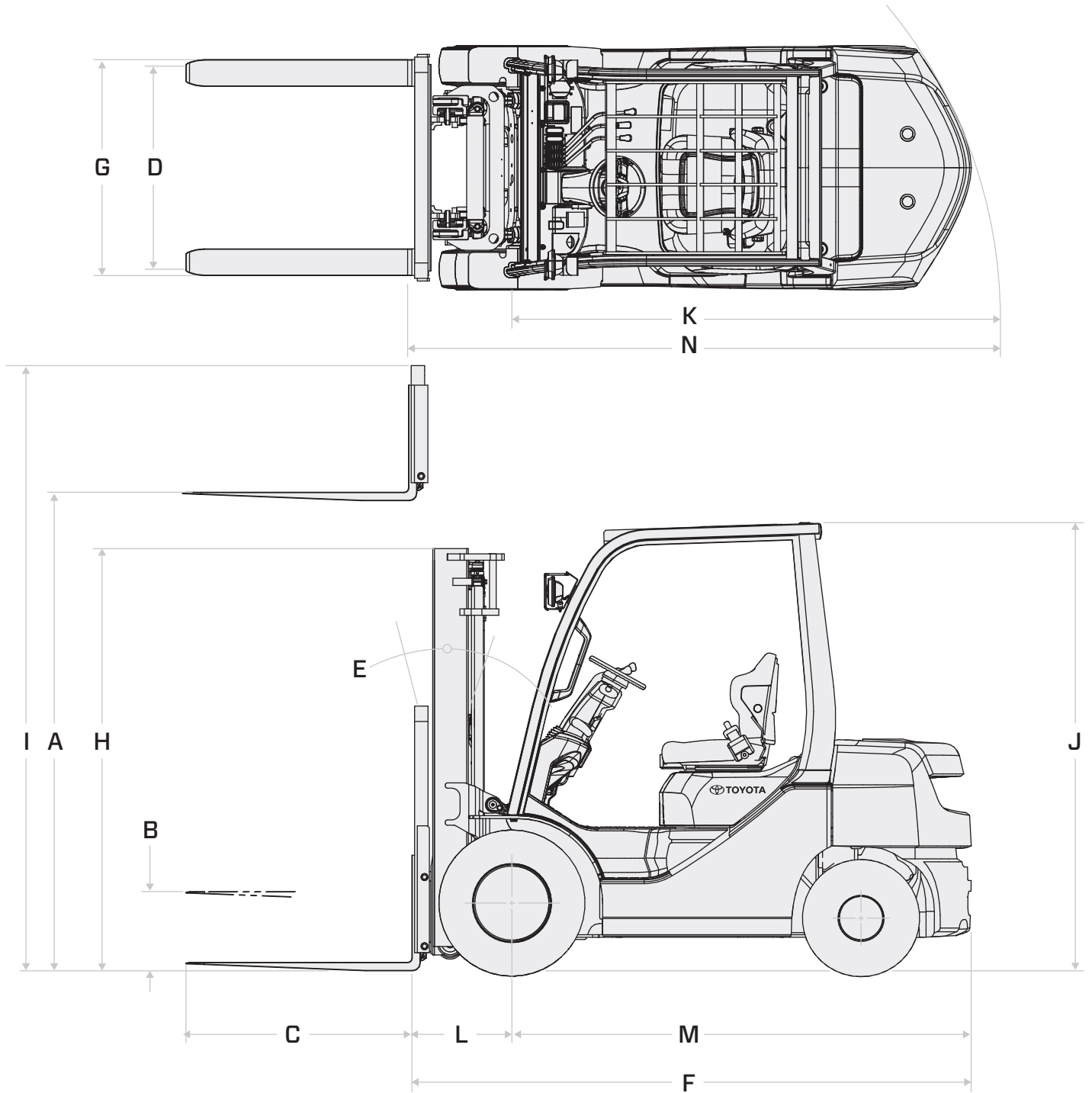

# MAST SPECIFICATIONS

MAST TYPE	MAXIMUM FORK HEIGHT (TOP OF FORKS)	OVERALL HEIGHT				FREE-LIFT		SINGLE TIRE			
		LOWERED	EXTENDED		WITHOUT LOAD BACKREST	WITH STANDARD LOAD BACKREST <sup>1</sup>	TILT RANGE		LOAD CAPACITY AT 24 IN. (610 MM) LOAD CENTER		
			WITHOUT LOAD BACKREST	WITH STANDARD LOAD BACKREST <sup>1</sup>			FWD	BWD	NARROW TREAD	WIDE TREAD	
	in (mm)	in (mm)	in (mm)	in (mm)	in (mm)	in (mm)	deg	deg	lb (kg)	lb (kg)	
<b>50-8FGU15 / 40-8FGU15</b>											
Wide Visible (V)	80 (2035)	58.9 (1495)	104.1 (2645)	128.1 (3255)	5.7 (145)	5.7 (145)	6	11	3000 (1350)	3000 (1350)	
	119 (3035)	78.5 (1995)	143.5 (3645)	167.5 (4255)	5.7 (145)	5.7 (145)	6	11	3000 (1350)	3000 (1350)	
	131 (3335)	84.5 (2145)	155.3 (3945)	179.3 (4555)	5.7 (145)	5.7 (145)	6	11	3000 (1350)	3000 (1350)	
	139 (3535)	88.4 (2245)	163.2 (4145)	187.2 (4755)	5.7 (145)	5.7 (145)	6	11	3000 (1350)	3000 (1350)	
	147 (3735)	94.7 (2405)	171.1 (4345)	195.1 (4955)	5.7 (145)	5.7 (145)	6	11	3000 (1350)	3000 (1350)	
Full Free-Lift 2-Stage (FV)	158.5 (4035)	102.2 (2595)	182.9 (4645)	206.9 (5255)	5.7 (145)	5.7 (145)	6	11	3000 (1350)	3000 (1350)	
	119 (3035)	78.5 (1995)	141.9 (3605)	167.5 (4255)	56.1 (1430)	30.5 (775)	6	11	3000 (1350)	3000 (1350)	
	131 (3335)	84.5 (2145)	153.7 (3905)	179.3 (4555)	62 (1580)	36.4 (925)	6	11	3000 (1350)	3000 (1350)	
Full Free-Lift 3-Stage (FSV)	139 (3535)	88.4 (2245)	161.6 (4105)	187.2 (4755)	65.9 (1680)	40.4 (1025)	6	11	3000 (1350)	3000 (1350)	
	158.5 (4035)	74.6 (1895)	180.1 (4575)	206.9 (5255)	53.3 (1360)	25.0 (635)	6	6	2850 (1300)	2850 (1300)	
	170.5 (4335)	78.5 (1995)	191.9 (4875)	218.7 (5555)	57.3 (1460)	28.9 (735)	6	6	2800 (1250)	2850 (1300)	
	189 (4800)	84.4 (2145)	209.6 (5325)	236.6 (6010)	63.2 (1610)	34.8 (885)	6	6	2750 (1250)	2800 (1250)	
	198 (5035)	88.4 (2245)	219.5 (5575)	246.3 (6255)	67.1 (1710)	38.8 (985)	6	6	2650 (1200)	2750 (1250)	
	217.5 (5535)	94.7 (2405)	239.2 (6075)	265.9 (6755)	73.4 (1870)	45.1 (1145)	6	6	2050 (950)	2200 (1000)	
237.5 (6035)	102.2 (2595)	258.9 (6575)	285.6 (7255)	80.9 (2060)	52.6 (1335)	6	6	1500 (700)	1650 (750)		

MAST TYPE	MAXIMUM FORK HEIGHT (TOP OF FORKS)	OVERALL HEIGHT				FREE-LIFT		SINGLE TIRE			
		LOWERED	EXTENDED		WITHOUT LOAD BACKREST	WITH STANDARD LOAD BACKREST <sup>1</sup>	TILT RANGE		LOAD CAPACITY AT 24 IN. (610 MM) LOAD CENTER		
			WITHOUT LOAD BACKREST	WITH STANDARD LOAD BACKREST <sup>1</sup>			FWD	BWD	NARROW TREAD	WIDE TREAD	
	in (mm)	in (mm)	in (mm)	in (mm)	in (mm)	in (mm)	deg	deg	lb (kg)	lb (kg)	
<b>50-8FGU18 / 40-8FGU18</b>											
Wide Visible (V)	80 (2035)	58.9 (1495)	104.1 (2645)	128.1 (3255)	5.7 (145)	5.7 (145)	6	11	3500 (1600)	3500 (1600)	
	119 (3035)	78.5 (1995)	143.5 (3645)	167.5 (4255)	5.7 (145)	5.7 (145)	6	11	3500 (1600)	3500 (1600)	
	131 (3335)	84.5 (2145)	155.3 (3945)	179.3 (4555)	5.7 (145)	5.7 (145)	6	11	3500 (1600)	3500 (1600)	
	139 (3535)	88.4 (2245)	163.2 (4145)	187.2 (4755)	5.7 (145)	5.7 (145)	6	11	3500 (1600)	3500 (1600)	
	147 (3735)	94.7 (2405)	171.1 (4345)	195.1 (4955)	5.7 (145)	5.7 (145)	6	11	3500 (1600)	3500 (1600)	
Full Free-Lift 2-Stage (FV)	158.5 (4035)	102.2 (2595)	182.9 (4645)	206.9 (5255)	5.7 (145)	5.7 (145)	6	11	3400 (1550)	3500 (1600)	
	119 (3035)	78.5 (1995)	141.9 (3605)	167.5 (4255)	56.1 (1430)	30.5 (775)	6	11	3500 (1600)	3500 (1600)	
	131 (3335)	84.5 (2145)	153.7 (3905)	179.3 (4555)	62 (1580)	36.4 (925)	6	11	3500 (1600)	3500 (1600)	
Full Free-Lift 3-Stage (FSV)	139 (3535)	88.4 (2245)	161.6 (4105)	187.2 (4755)	65.9 (1680)	40.4 (1025)	6	11	3500 (1600)	3500 (1600)	
	158.5 (4035)	74.6 (1895)	180.1 (4575)	206.9 (5255)	53.3 (1360)	25.0 (635)	6	6	3200 (1450)	3200 (1450)	
	170.5 (4335)	78.5 (1995)	191.9 (4875)	218.7 (5555)	57.3 (1460)	28.9 (735)	6	6	3150 (1400)	3200 (1450)	
	189 (4800)	84.4 (2145)	209.6 (5325)	236.6 (6010)	63.2 (1610)	34.8 (885)	6	6	2900 (1300)	3050 (1400)	
	198 (5035)	88.4 (2245)	219.5 (5575)	246.3 (6255)	67.1 (1710)	38.8 (985)	6	6	2550 (1150)	3000 (1350)	
	217.5 (5535)	94.7 (2405)	239.2 (6075)	265.9 (6755)	73.4 (1870)	45.1 (1145)	6	6	1850 (850)	2400 (1100)	
237.5 (6035)	102.2 (2595)	258.9 (6575)	285.6 (7255)	80.9 (2060)	52.6 (1335)	6	6	1300 (600)	1750 (800)		

<sup>1</sup> Height of standard load backrest is 48" (1220 mm).

MAST TYPE	MAXIMUM FORK HEIGHT (TOP OF FORKS)	OVERALL HEIGHT			FREE-LIFT		SINGLE TIRE			DUAL TIRE	
		LOWERED	EXTENDED		WITHOUT LOAD BACKREST	WITH STANDARD LOAD BACKREST <sup>1</sup>	TILT RANGE	LOAD CAPACITY AT 24 IN. (610 MM) LOAD CENTER		TILT RANGE	LOAD CAPACITY AT 24 IN. (610 MM) LOAD CENTER
			WITHOUT LOAD BACKREST	WITH STANDARD LOAD BACKREST <sup>1</sup>				FWD / BWD	NARROW TREAD		
	in (mm)	in (mm)	in (mm)	in (mm)	in (mm)	in (mm)	deg	lb (kg)	lb (kg)	deg	lb (kg)
<b>50-8FGU20 / 40-8FGU20</b>											
Wide Visible (V)	80 (2040)	58.9 (1495)	104.7 (2660)	128.3 (3260)	6.1 (155)	6.1 (155)	6 / 11	4000 (1800)	4000 (1800)	6 / 11	4000 (1800)
	119.5 (3040)	78.5 (1995)	144.1 (3660)	167.7 (4260)	6.1 (155)	6.1 (155)	6 / 11	4000 (1800)	4000 (1800)	6 / 11	4000 (1800)
	131.5 (3340)	84.5 (2145)	155.9 (3960)	179.5 (4560)	6.1 (155)	6.1 (155)	6 / 11	4000 (1800)	4000 (1800)	6 / 11	4000 (1800)
	139 (3540)	88.4 (2245)	163.8 (4160)	187.4 (4760)	6.1 (155)	6.1 (155)	6 / 11	4000 (1800)	4000 (1800)	6 / 11	4000 (1800)
	147 (3740)	94.7 (2405)	171.7 (4360)	195.3 (4960)	6.1 (155)	6.1 (155)	6 / 11	4000 (1800)	4000 (1800)	6 / 11	4000 (1800)
Full Free-Lift 2-Stage (FV)	159 (4040)	102.2 (2595)	183.5 (4660)	207.1 (5260)	6.1 (155)	6.1 (155)	6 / 11	4000 (1800)	4000 (1800)	6 / 11	4000 (1800)
	119.5 (3040)	78.5 (1995)	143.5 (3645)	167.7 (4260)	55.1 (1400)	30.5 (775)	6 / 11	4000 (1800)	4000 (1800)	6 / 11	4000 (1800)
	131.5 (3340)	84.5 (2145)	151.4 (3845)	179.5 (4560)	61 (1550)	36.4 (925)	6 / 11	4000 (1800)	4000 (1800)	6 / 11	4000 (1800)
Full Free-Lift 3-Stage (FSV)	139 (3540)	88.4 (2245)	163.2 (4145)	187.4 (4760)	65 (1650)	40.4 (1025)	6 / 11	4000 (1800)	4000 (1800)	6 / 11	4000 (1800)
	159 (4040)	74.6 (1895)	181.5 (4610)	206.7 (5250)	52.4 (1330)	26.6 (675)	6 / 6	4000 (1800)	4000 (1800)	6 / 6	4000 (1800)
	170.5 (4340)	78.5 (1995)	193.3 (4910)	218.5 (5550)	56.3 (1430)	30.5 (775)	6 / 6	4000 (1800)	4000 (1800)	6 / 6	4000 (1800)
	189 (4800)	84.5 (2145)	211.4 (5370)	236.6 (6010)	62.2 (1580)	36.4 (915)	6 / 6	3900 (1750)	4000 (1800)	6 / 6	4000 (1800)
	198 (5040)	88.4 (2245)	220.9 (5610)	246.1 (6250)	66.1 (1680)	40.4 (1015)	6 / 6	3550 (1600)	4000 (1800)	6 / 6	4000 (1800)
	218 (5540)	94.7 (2405)	240.6 (6110)	265.7 (6750)	72.4 (1840)	46.7 (1185)	6 / 6	2800 (1250)	3500 (1600)	6 / 6	3750 (1700)
	237.5 (6040)	102.2 (2595)	260.2 (6610)	285.4 (7250)	79.9 (2030)	54.2 (1375)	6 / 6	2000 (900)	2550 (1150)	6 / 6	3300 (1500)
	257.5 (6540)	112 (2845)	279.9 (7110)	305.1 (7750)	89.8 (2280)	64 (1625)	—	—	—	6 / 6	3200 (1450)
Full Free-Lift 4-Stage (QFV)	277 (7040)	121.9 (3095)	299.6 (7610)	324.8 (8250)	99.6 (2530)	73.9 (1875)	—	—	—	6 / 6	2600 (1200)
	240 (6100)	84.8 (2155)	263.4 (6690)	289.4 (7350)	61 (1550)	35 (895)	6 / 3	—	—	6 / 3	—
	258 (6600)	90.7 (2305)	281.5 (7150)	307.5 (7810)	67 (1700)	41 (1045)	6 / 3	—	2600 (1170)	6 / 3	—

MAST TYPE	MAXIMUM FORK HEIGHT (TOP OF FORKS)	OVERALL HEIGHT			FREE-LIFT		SINGLE TIRE			DUAL TIRE	
		LOWERED	EXTENDED		WITHOUT LOAD BACKREST	WITH STANDARD LOAD BACKREST <sup>1</sup>	TILT RANGE	LOAD CAPACITY AT 24 IN. (610 MM) LOAD CENTER		TILT RANGE	LOAD CAPACITY AT 24 IN. (610 MM) LOAD CENTER
			WITHOUT LOAD BACKREST	WITH STANDARD LOAD BACKREST <sup>1</sup>				FWD / BWD	NARROW TREAD		
	in (mm)	in (mm)	in (mm)	in (mm)	in (mm)	in (mm)	deg	lb (kg)	lb (kg)	deg	lb (kg)
<b>50-8FGU25 / 40-8FGU25</b>											
Wide Visible (V)	80 (2040)	58.9 (1495)	104.7 (2660)	128.3 (3260)	6.1 (155)	6.1 (155)	6 / 11	5000 (2250)	5000 (2250)	6 / 11	5000 (2250)
	119.5 (3040)	78.5 (1995)	144.1 (3660)	167.7 (4260)	6.1 (155)	6.1 (155)	6 / 11	5000 (2250)	5000 (2250)	6 / 11	5000 (2250)
	131.5 (3340)	84.5 (2145)	155.9 (3960)	179.5 (4560)	6.1 (155)	6.1 (155)	6 / 11	5000 (2250)	5000 (2250)	6 / 11	5000 (2250)
	139 (3540)	88.4 (2245)	163.8 (4160)	187.4 (4760)	6.1 (155)	6.1 (155)	6 / 11	5000 (2250)	5000 (2250)	6 / 11	5000 (2250)
	147 (3740)	94.7 (2405)	171.7 (4360)	195.3 (4960)	6.1 (155)	6.1 (155)	6 / 11	5000 (2250)	5000 (2250)	6 / 11	5000 (2250)
Full Free-Lift 2-Stage (FV)	159 (4040)	102.2 (2595)	183.5 (4660)	207.1 (5260)	6.1 (155)	6.1 (155)	6 / 11	5000 (2250)	5000 (2250)	6 / 11	5000 (2250)
	119.5 (3040)	78.5 (1995)	143.5 (3645)	167.7 (4260)	55.1 (1400)	30.5 (775)	6 / 11	5000 (2250)	5000 (2250)	6 / 11	5000 (2250)
	131.5 (3340)	84.5 (2145)	151.4 (3845)	179.5 (4560)	61 (1550)	36.4 (925)	6 / 11	5000 (2250)	5000 (2250)	6 / 11	5000 (2250)
Full Free-Lift 3-Stage (FSV)	139 (3540)	88.4 (2245)	163.2 (4145)	187.4 (4760)	65 (1650)	40.4 (1025)	6 / 11	5000 (2250)	5000 (2250)	6 / 11	5000 (2250)
	159 (4040)	74.6 (1895)	181.5 (4610)	206.7 (5250)	52.4 (1330)	26.6 (675)	6 / 6	5000 (2250)	5000 (2250)	6 / 6	5000 (2250)
	170.5 (4340)	78.5 (1995)	193.3 (4910)	218.5 (5550)	56.3 (1430)	30.5 (775)	6 / 6	5000 (2250)	5000 (2250)	6 / 6	5000 (2250)
	189 (4800)	84.5 (2145)	211.4 (5370)	236.6 (6010)	62.2 (1580)	36.4 (915)	6 / 6	3950 (1800)	4850 (2200)	6 / 6	4950 (2250)
	198 (5040)	88.4 (2245)	220.9 (5610)	246.1 (6250)	66.1 (1680)	40.4 (1015)	6 / 6	3550 (1600)	4500 (2050)	6 / 6	4850 (2200)
	218 (5540)	94.7 (2405)	240.6 (6110)	265.7 (6750)	72.4 (1840)	46.7 (1185)	6 / 6	2850 (1300)	3850 (1750)	6 / 6	4500 (2050)
	237.5 (6040)	102.2 (2595)	260.2 (6610)	285.4 (7250)	79.9 (2030)	54.2 (1375)	6 / 6	2000 (900)	2550 (1150)	6 / 6	3500 (1600)
	257.5 (6540)	112 (2845)	279.9 (7110)	305.1 (7750)	89.8 (2280)	64 (1625)	—	—	—	6 / 6	3200 (1450)
Full Free-Lift 4-Stage (QFV)	277 (7040)	121.9 (3095)	299.6 (7610)	324.8 (8250)	99.6 (2530)	73.9 (1875)	—	—	—	6 / 6	2500 (1150)
	240 (6100)	84.8 (2155)	263.4 (6690)	289.4 (7350)	61 (1550)	35 (895)	6 / 3	—	3800 (1720)	6 / 3	—
	258 (6600)	90.7 (2305)	281.5 (7150)	307.5 (7810)	67 (1700)	41 (1045)	6 / 3	—	—	6 / 3	—

<sup>1</sup> Height of standard load backrest is 48" (1220 mm).  
Wide tread standard for all models with a 189" & higher FSV mast. Wide tread deduct option (G00F) will configure back to narrow tread.  
High-lift SAS active mast functions not available on 80V mast.  
Must have Dual Drive Tires (F00C) at extra cost for 258 FSV, 277 FSV.  
Please contact your local, authorized Toyota Dealer for a complete list of available options.

# MAST SPECIFICATIONS

MAST TYPE	MAXIMUM FORK HEIGHT (TOP OF FORKS)	OVERALL HEIGHT				FREE-LIFT		SINGLE TIRE			DUAL TIRE	
		LOWERED	EXTENDED		WITHOUT LOAD BACKREST	WITH STANDARD LOAD BACKREST <sup>1</sup>	TILT RANGE	LOAD CAPACITY AT 24 IN. (610 MM) LOAD CENTER		TILT RANGE	LOAD CAPACITY AT 24 IN. (610 MM) LOAD CENTER	
			WITHOUT LOAD BACKREST	WITH STANDARD LOAD BACKREST <sup>1</sup>				FWD / BWD	NARROW TREAD			WIDE TREAD
in (mm)	in (mm)	in (mm)	in (mm)	in (mm)	in (mm)	deg	lb (kg)	lb (kg)	deg	lb (kg)		
<b>50-8FGU30 / 40-8FGU30</b>												
Wide Visible (V)	80.5 (2045)	59.6 (1515)	108.3 (2750)	128.5 (3265)	5.3 (135)	5.3 (135)	6 / 11	6000 (2700)	6000 (2700)	6 / 11	6000 (2700)	
	119.5 (3045)	79.3 (2015)	147.6 (3750)	167.9 (4265)	5.3 (135)	5.3 (135)	6 / 11	6000 (2700)	6000 (2700)	6 / 11	6000 (2700)	
	131.5 (3345)	85 (2165)	159.4 (4050)	179.7 (4565)	5.3 (135)	5.3 (135)	6 / 11	6000 (2700)	6000 (2700)	6 / 11	6000 (2700)	
	139.5 (3545)	89.2 (2265)	167.3 (4250)	187.6 (4765)	5.3 (135)	5.3 (135)	6 / 11	6000 (2700)	6000 (2700)	6 / 11	6000 (2700)	
	147 (3745)	95.5 (2425)	175.2 (4450)	195.5 (4965)	5.3 (135)	5.3 (135)	6 / 11	6000 (2700)	6000 (2700)	6 / 11	6000 (2700)	
	159 (4045)	103 (2615)	187 (4750)	207.3 (5265)	5.3 (135)	5.3 (135)	6 / 11	6000 (2700)	6000 (2700)	6 / 11	6000 (2700)	
Full Free-Lift 2-Stage (FV)	119.5 (3045)	79.3 (2015)	144.1 (3660)	167.9 (4265)	55.1 (1400)	31.3 (795)	6 / 11	6000 (2700)	6000 (2700)	6 / 11	6000 (2700)	
	131.5 (3345)	85.0 (2165)	155.9 (3960)	179.7 (4565)	61 (1550)	37.2 (945)	6 / 11	6000 (2700)	6000 (2700)	6 / 11	6000 (2700)	
	139.5 (3545)	89.2 (2265)	163.8 (4160)	187.6 (4765)	65 (1650)	41.2 (1045)	6 / 11	6000 (2700)	6000 (2700)	6 / 11	6000 (2700)	
Full Free-Lift 3-Stage (FSV)	159 (4045)	79.3 (2015)	183.5 (4660)	207.3 (5265)	55.1 (1400)	31.3 (795)	6 / 6	6000 (2750)	6000 (2750)	6 / 6	6000 (2750)	
	171 (4345)	85.2 (2165)	195.3 (4960)	219.1 (5565)	61 (1550)	37.2 (945)	6 / 6	6000 (2750)	6000 (2750)	6 / 6	6000 (2750)	
	187 (4750)	89.2 (2265)	211.0 (5360)	235 (5970)	65 (1650)	41.2 (1045)	6 / 6	6000 (2750)	6000 (2750)	6 / 6	6000 (2750)	
	198.5 (5045)	95.5 (2425)	222.8 (5660)	246.7 (6265)	71.3 (1810)	47.5 (1205)	6 / 6	5600 (2550)	5800 (2650)	6 / 6	6000 (2700)	
	218 (5545)	103 (2615)	242.5 (6160)	266.3 (6765)	78.7 (2000)	55 (1395)	6 / 6	4200 (1900)	5300 (2400)	6 / 6	5600 (2550)	
	237.5 (6045)	112.8 (2865)	262.2 (6660)	286 (7265)	88.6 (2250)	64.8 (1645)	6 / 6	3100 (1400)	3500 (1600)	6 / 6	4300 (1950)	
	257.5 (6545)	122.6 (3115)	281.9 (7160)	305.7 (7765)	98.4 (2500)	74.6 (1895)	—	—	—	6 / 6	3500 (1600)	
	277 (7045)	132.5 (3365)	301.6 (7660)	325.4 (8265)	108.3 (2750)	84.5 (2145)	—	—	—	6 / 6	2600 (1200)	
Full Free-Lift 4-Stage (QFV)	240 (6100)	84.8 (2155)	263.4 (6690)	289.4 (7350)	61 (1550)	35 (895)	6 / 3	—	4900 (2220)	6 / 3	—	
	258 (6600)	90.7 (2305)	281.5 (7150)	307.5 (7810)	67 (1700)	41 (1045)	6 / 3	—	—	6 / 3	—	

MAST TYPE	MAXIMUM FORK HEIGHT (TOP OF FORKS)	OVERALL HEIGHT				FREE-LIFT		SINGLE TIRE			DUAL TIRE	
		LOWERED	EXTENDED		WITHOUT LOAD BACKREST	WITH STANDARD LOAD BACKREST <sup>1</sup>	TILT RANGE	LOAD CAPACITY AT 24 IN. (610 MM) LOAD CENTER		TILT RANGE	LOAD CAPACITY AT 24 IN. (610 MM) LOAD CENTER	
			WITHOUT LOAD BACKREST	WITH STANDARD LOAD BACKREST <sup>1</sup>				FWD / BWD	NARROW TREAD			WIDE TREAD
in (mm)	in (mm)	in (mm)	in (mm)	in (mm)	in (mm)	deg	lb (kg)	lb (kg)	deg	lb (kg)		
<b>50-8FGU32 / 40-8FGU32</b>												
Wide Visible (V)	80.5 (2045)	59.6 (1515)	108.3 (2750)	128.5 (3265)	5.3 (135)	5.3 (135)	6 / 11	6500 (3000)	6500 (3000)	6 / 11	6500 (3000)	
	119.5 (3045)	79.3 (2015)	147.6 (3750)	167.9 (4265)	5.3 (135)	5.3 (135)	6 / 11	6500 (3000)	6500 (3000)	6 / 11	6500 (3000)	
	131.5 (3345)	85 (2165)	159.4 (4050)	179.7 (4565)	5.3 (135)	5.3 (135)	6 / 11	6500 (3000)	6500 (3000)	6 / 11	6500 (3000)	
	139.5 (3545)	89.2 (2265)	167.3 (4250)	187.6 (4765)	5.3 (135)	5.3 (135)	6 / 11	6500 (3000)	6500 (3000)	6 / 11	6500 (3000)	
	147 (3745)	95.5 (2425)	175.2 (4450)	195.5 (4965)	5.3 (135)	5.3 (135)	6 / 11	6500 (3000)	6500 (3000)	6 / 11	6500 (3000)	
	159 (4045)	103 (2615)	187 (4750)	207.3 (5265)	5.3 (135)	5.3 (135)	6 / 11	6500 (3000)	6500 (3000)	6 / 11	6500 (3000)	
Full Free-Lift 2-Stage (FV)	119.5 (3045)	79.3 (2015)	149.2 (3790)	167.9 (4265)	50 (1270)	31.3 (795)	6 / 11	6500 (3000)	6500 (3000)	6 / 11	6500 (3000)	
	131.5 (3345)	85.0 (2165)	161.0 (4090)	179.7 (4565)	55.9 (1420)	37.2 (945)	6 / 11	6500 (3000)	6500 (3000)	6 / 11	6500 (3000)	
	139.5 (3545)	89.2 (2265)	168.3 (4290)	187.6 (4765)	59.8 (1520)	41.2 (1045)	6 / 11	6500 (3000)	6500 (3000)	6 / 11	6500 (3000)	
Full Free-Lift 3-Stage (FSV)	159 (4045)	79.3 (2015)	188.6 (4790)	207.3 (5265)	50 (1270)	31.3 (795)	6 / 6	6500 (3000)	6500 (3000)	6 / 6	6500 (3000)	
	171 (4345)	85.2 (2165)	200.4 (5090)	219.1 (5565)	55.9 (1420)	37.2 (945)	6 / 6	6500 (3000)	6500 (3000)	6 / 6	6500 (3000)	
	187 (4750)	89.2 (2265)	216.1 (5490)	235 (5970)	59.8 (1520)	41.2 (1045)	6 / 6	6500 (3000)	6500 (3000)	6 / 6	6500 (3000)	
	198.5 (5045)	95.5 (2425)	228.0 (5790)	246.7 (6265)	66.1 (1680)	47.5 (1205)	6 / 6	5750 (2600)	6400 (2900)	6 / 6	6500 (2950)	
	218 (5545)	103 (2615)	247.6 (6290)	266.3 (6765)	73.6 (1870)	55 (1395)	6 / 6	4200 (1900)	5500 (2500)	6 / 6	5800 (2650)	
	237.5 (6045)	112.8 (2865)	267.3 (6790)	286 (7265)	83.5 (2120)	64.8 (1645)	6 / 6	3300 (1500)	4000 (1800)	6 / 6	4500 (2050)	
	257.5 (6545)	122.6 (3115)	287.0 (7290)	305.7 (7765)	93.3 (2370)	74.6 (1895)	—	—	—	6 / 6	3500 (1600)	
	277 (7045)	132.5 (3365)	306.7 (7790)	325.4 (8265)	103.1 (2620)	84.5 (2145)	—	—	—	6 / 6	2300 (1050)	
Full Free-Lift 4-Stage (QFV)	240 (6100)	84.8 (2155)	263.4 (6690)	289.4 (7350)	61 (1550)	35 (895)	6 / 3	—	3800 (1720)	6 / 3	—	
	258 (6600)	90.7 (2305)	281.5 (7150)	307.5 (7810)	67 (1700)	40 (1010)	6 / 3	—	3200 (1450)	6 / 3	—	

<sup>1</sup> Height of standard load backrest is 48" (1220 mm).  
 High-lift SAS active mast functions not available on 80V mast.  
 Must have Dual Drive Tires (FOOC) at extra cost for 258 FSV, 277 FSV.  
 Please contact your local, authorized Toyota Dealer for a complete list of available options.





# “I’M HERE TO MAKE SURE YOUR FORKLIFTS DON’T TAKE VACATION DAYS.”

Butch - 360 Technician, ProLift, Cincinnati, Ohio



## HELP IS ALWAYS HERE WITH TOYOTA 360 SUPPORT.

The industry’s best and most comprehensive dealer network quickly delivers Toyota Certified Technicians to your work site. These specially trained technicians can also help assess your warehouse and facility needs to recommend the right equipment for the job. And with the largest fleet of material handling equipment, Toyota 360 keeps your business running at full speed.

[ToyotaForklift.com/360-Support](http://ToyotaForklift.com/360-Support)



**YOUR BUSINESS IS RIDING ON IT.**

Some product features described herein are optional. Please consult your dealer for specifications. Details of specifications and equipment are based on information available at time of printing and may change without notice. Photos may not reflect physical trucks.

