

3-WHEEL ELECTRIC



3000 - 4000 LBS.

SPECIFICATIONS



8FBE15U-20U | 8FBES15U | 8FBEH18U

CLASS

1

ELECTRIC MOTOR RIDERS

ToyotaForklift.com

3-WHEEL ELECTRIC

CAPACITY
3000 - 4000 LBS.

WHEELBASE
47.6 - 55.1 IN.

LIFT HEIGHT
277.5 IN.

INDUSTRIES



STANDARD FEATURES

SUPPORT

- Active Mast Control (AMC)
 - Forward tilt angle control
 - Rear tilt speed control
 - Lift speed limitation with forward tilt
- Wet disc brakes
- Operator Presence Sensing System (OPSS)
- Momentary hold/controlled descent
- Key lowering interlock
- Automatic Parking Brake
- Electric horn
- Manual return to neutral
- Turn speed control

PERFORMANCE

- 36-Volt electrical system
- AC drive system
- AC lift system
- Programmable hydraulics
- UL-approved model type E
- Transverse-mounted AC drive motors
- Power select functions (E.S.P.H.C.)
- Color LCD Multifunction Display
 - Time & date
- Speedometer
- Multifunction hour meter
- Battery capacity indicator
- Parking brake indicator
- Over-discharge warning (lift interrupt)
- Mast tilt indicator
- Maximum speed limiter
- Rollback control indicator
- Key switch ON hour meter
- Power keep function
- 3-way hydraulic control valve
- Programmable auto-off system
- Two forms of energy regeneration
 - Coast control
 - Plug braking
- Automatic Parking Brake

BODY/EXTERIOR DESIGN

- Wide-view 2-stage mast (V)
- Punched plate entry/exit step
- Bolt-on overhead guard
- Smooth cushion tires (dual steer tires)
- 36"-wide ITA class II fork carriage
- 48" load backrest extension
- 90°-wide-opening battery hood
- 42" tapered forks
- 81" OHG height
- SB 350 battery connector (gray)
- Drawbar pin

OPERABILITY & ERGONOMICS

- Strategically configured instrument display
- On-demand, hydrostatic power steering
- Cowl-mounted hydraulic controls
- Automatic fork-leveling control
- Large dual operator assist grips
- Operator restraint system (ORS)
- with full-suspension seat
- Retractable seat belt
- Electric directional shift control
- Memory-tilt steering column
- Hood-integrated paper clip
- Heavy-duty slip-resistant floor mat
- Two-spoke steering wheel
- Integrated switch for headlight & turn signal
- Dash-mounted cup holder
- Curvilinear OHG front pillars
- 11.8" diameter steering wheel
- Orange seatbelt

SERVICEABILITY

- Maintenance-free AC motors
- Thermal protection monitor
- Easy-access controllers
- Programmable maintenance timer
- Battery compartment hood assist damper
- Easy access no-tools floorboard
- Built-in analyzer
- Self-diagnostics

OPTIONAL EQUIPMENT

- UL-approved model type "EE"
- UL-approved model type "ES"
- 48-Volt electrical system
- Air-filled pneumatic tires (3-3.5K)
- Solid pneumatic tires
- Non-marking tires
- Mini-lever controls
- Cold storage model
- Battery roll-out or slide-out
- 4-way hydraulic control valve
- Battery compartment side panels
- EZ Pedal (foot directional control)
- Premium, full-suspension cloth seat
- String cutter
- Rear assist grip with horn button
- Lithium-ion Battery
- Seatbelt Interlock
- Special paint (1-2 colors)
- Cloth 12° swivel seat
- Battery connector color (blue, red, or yellow)
- SEnS Smart Environment Sensor®
- SEnS+ Smart Environment Sensor Plus®
- Drive-in rack OHG
- Rearview mirrors (left & right)
- 12-Volt power supply
- Inset headlights within OHG
- Operator compartment light
- Strobe lights (yellow or red)
- LED front headlights
- Front/rear combination lights
- LED rear combination lights
- Rear working light
- Key-off headlight system
- Adjustable volume back up alarm (smart alarm)
- Anti-static strap
- Wide-view full free-lift 2-stage mast (FV)
- Wide-view full free-lift 3-stage mast (FSV)
- Wide-view full free-lift 4-stage mast (QFV)
- Polycarbonate OHG cover
- Slope Assist
- Keyless ignition
- Fully tapered & polished forks (FTP)
- 40"-wide carriage
- Various load backrest extension heights
- Mast tilt (bottler's tilt 10° forward/5° backward)
- Tilt cylinder boots
- Front protector cover
- Side hosing termination
- Fire extinguisher
- Quick disconnects (single & dual)
- Steering wheel with knob
- Synchronized steering (steering wheel knob is recommended)
- Clamp release interlock systems
- Auto speed control
- Emergency power shutdown button
- Integral side-shifting fork positioner
- Reverse activated blue spotlight
- Fast charge
- EZ Control Joystick®
- EZ Fingertip Controls®

TRUCK SPECIFICATIONS

MODEL NUMBERS

GENERAL DATA				8FBE15U	8FBES15U	8FBE18U	8FBEH18U	8FBE20U	
Load Capacity (with 24" load center)	lb			3000	3000	3500	3500	4000	
Service Brake / Parking Brake				Wet Disc (Foot) / Automatic (Electric)					
Power Type				Battery					
EXTERIOR DIMENSIONS				8FBE15U	8FBES15U	8FBE18U	8FBEH18U	8FBE20U	
A Maximum Fork Height (MFH)	in			119	119	119	119	119.5	
B Mast Lowered Height	in			77.6	77.6	77.6	77.6	77.6	
C Mast Extended Height (top of load backrest)	in			167.5	167.5	167.5	167.5	167.7	
D Free-Lift (top of forks)	in			5.7	5.7	5.7	5.7	5.9	
E Load Distance ¹	in			13.8	13.8	13.8	13.8	14.4	
F Wheelbase	in			51.6	47.6	51.6	55.1	55.1	
G Fork Size (T x W x L)	in			1.4 x 4 x 42	1.4 x 4 x 42	1.4 x 4 x 42	1.4 x 4 x 42	1.6 x 5 x 42	
H Length to Fork Face	in			72	69	74.2	76.4	77.2	
I Overhead Guard Height	in			81	81	81	81	81	
J Tilt Range (forward / backward)	deg			5 / 6.5	5 / 6.5	5 / 6.5	5 / 6.5	5 / 6.5	
K Outside Turning Radius	in			58.3	55.1	60.5	62.8	62.8	
L Overall Width	in			41.5 [42.1]	41.5 [42.1]	41.5 [42.1]	41.5 [42.1]	41.5	
M Carriage Width	in			36	36	36	36	36	
N Tread Width	Front	in		34.5 [36]	34.5 [36]	34.5 [36]	34.5 [36]	34.5 [36]	
	Rear	in		6.9	6.9	6.9	6.9	6.9	
Basic Right-Angle Stacking Aisle Width ²	in (mm)			72.1 (1831)	68.9 (1750)	74.2 (1885)	76.6 (1946)	77.2 (1961)	
PERFORMANCE DATA				8FBE15U	8FBES15U	8FBE18U	8FBEH18U	8FBE20U	
Maximum Travel Speed (H-mode)	Fwd / Rvs - Full Load	36V	mph	9.9	9.9	9.9	9.9	9.7	
	Fwd / Rvs - Full Load	48V	mph	9.9	9.9	9.9	9.9	9.7 [
	Fwd / Rvs - No Load	36V	mph	9.9	9.9	9.9	9.9	9.9 [
	Fwd / Rvs - No Load	48V	mph	10.2	10.2	10.2 [10.2	9.9	
Lift Speed (V mast only)	Full Load	36V / 48V	fpm	77 / 94	77 / 94	71 / 89	71 / 89	67 / 83	
	No Load	36V / 48V	fpm	134 / 134	134 / 134	134 / 134	134 / 134	134 / 134	
Lowering Speed (V mast only)	Full Load		fpm	104	104	104	104	104	
	No Load		fpm	108	108	108	108	108	
Maximum Drawbar Pull	Full Load ³		lb	2560	2560	2540	2540	2500	
	No Load ³		lb	2540	2540	2540	2540	2520	
Maximum Gradeability	Full Load ³		%	27	25	24	24	22	
	No Load ³		%	24	22	22	24	22	
UNDERCLEARANCE				8FBE15U	8FBES15U	8FBE18U	8FBEH18U	8FBE20U	
Center of Wheelbase	in			3.3	3.3	3.3	3.3	3.3	
TRUCK WEIGHTS				8FBE15U	8FBES15U	8FBE18U	8FBEH18U	8FBE20U	
Gross Weight Without Battery	lb			4810 (2180)	5270 (2390)	5190 (2355)	4850 (2200)	5400 (2450)	
Weight Distribution (with standard battery)	Full Load	Front	lb	8320 (3775)	8450 (3830)	9140 (4145)	9280 (4210)	10200 (4625)	
		Rear	lb	1040 (470)	1300 (590)	1090 (495)	1170 (530)	1300 (590)	
	No Load	Front	lb	3120 (1415)	3070 (1390)	3080 (1400)	3380 (1530)	3420 (1550)	
		Rear	lb	3240 (1470)	3680 (1670)	3650 (1655)	3570 (1620)	4080 (1850)	
ATTACHMENT				8FBE15U	8FBES15U	8FBE18U	8FBEH18U	8FBE20U	
Attachment Max Operating Hydraulic Pressure	psi			2000	2000	2000	2000	2000	
TIRES				8FBE15U	8FBES15U	8FBE18U	8FBEH18U	8FBE20U	
Type (front / rear)				Cushion / Cushion [Pneumatic / Pneumatic]					
Size (OD x W x ID)	Drive			18 x 7 x 12-1/8 [18 x 7-8-16PR]	18 x 7 x 12-1/8 [18 x 7-8-16PR]	18 x 7 x 12-1/8 [18 x 7-8-16PR]	18 x 7 x 12-1/8 [18 x 7-8-16PR]	18 x 7 x 12-1/8 [18 x 7-8-16PR]	
	Steer			15 x 5 x 11-1/4 [16 x 6-8-10PR]	15 x 5 x 11-1/4 [16 x 6-8-10PR]	15 x 5 x 11-1/4 [16 x 6-8-10PR]	15 x 5 x 11-1/4 [16 x 6-8-10PR]	15 x 5 x 11-1/4 [16 x 6-8-10PR]	
POWER SYSTEM				8FBE15U	8FBES15U	8FBE18U	8FBEH18U	8FBE20U	
Battery	Voltage / Capacity (6-hour ratings)	STD	36V / 48V	Ah	595 / 375	510 / 360	595 / 375	765 / 660	765 / 660
		High	36V / 48V	Ah	880 / 660	660 / 440	880 / 660	1100 / 770	1100 / 770
Battery Compartment	Width		in	39.2	39.2	39.2	39.2	39.2	
	Length		in	21.7	17.7	21.7	25.1	25.1	
	Height		in	24.5	24.5	24.5	24.5	24.5	
Battery Weight	Maximum		lb (kg)	-	-	-	-	-	
	Minimum		lb (kg)	1543	1475	1543	2105	2105	
Electric Motors	Drive	36V / 48V	hp (kW)	4.8 x 2 / 5.0 x 2	4.8 x 2 / 5.0 x 2	4.8 x 2 / 5.0 x 2	4.8 x 2 / 5.0 x 2	4.8 x 2 / 5.0 x 2	
	Load Handling	36V / 48V	hp (kW)	12 / 12	12 / 12	12 / 12	12 / 12	12 / 12	
Control Type	Drive			MOSFET Transistor					
	Load Handling			MOSFET Transistor					

1 Centerline of front axle to front face of forks.
2 Add load length & aisle clearance.

3 3-minute rating computed values.
[] Pneumatic tire model specifications.

EXTERIOR DIMENSIONS

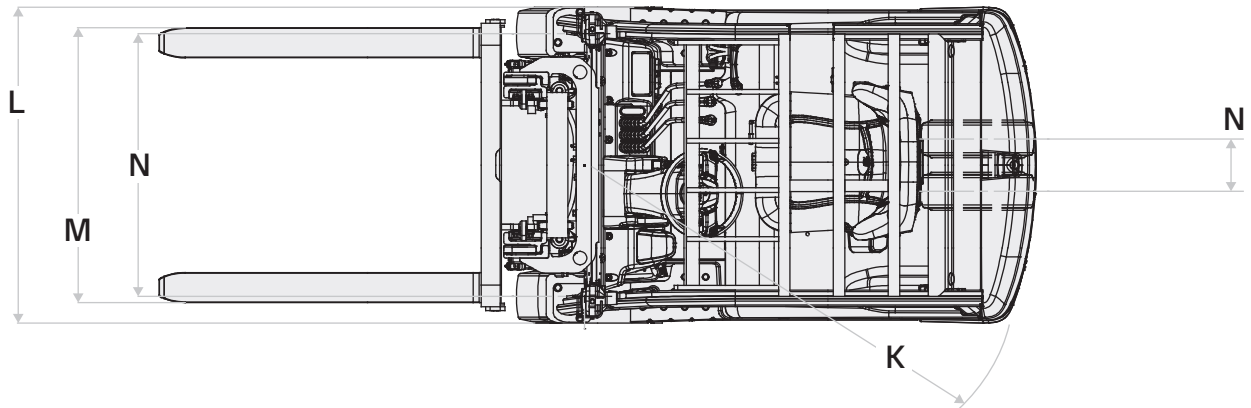
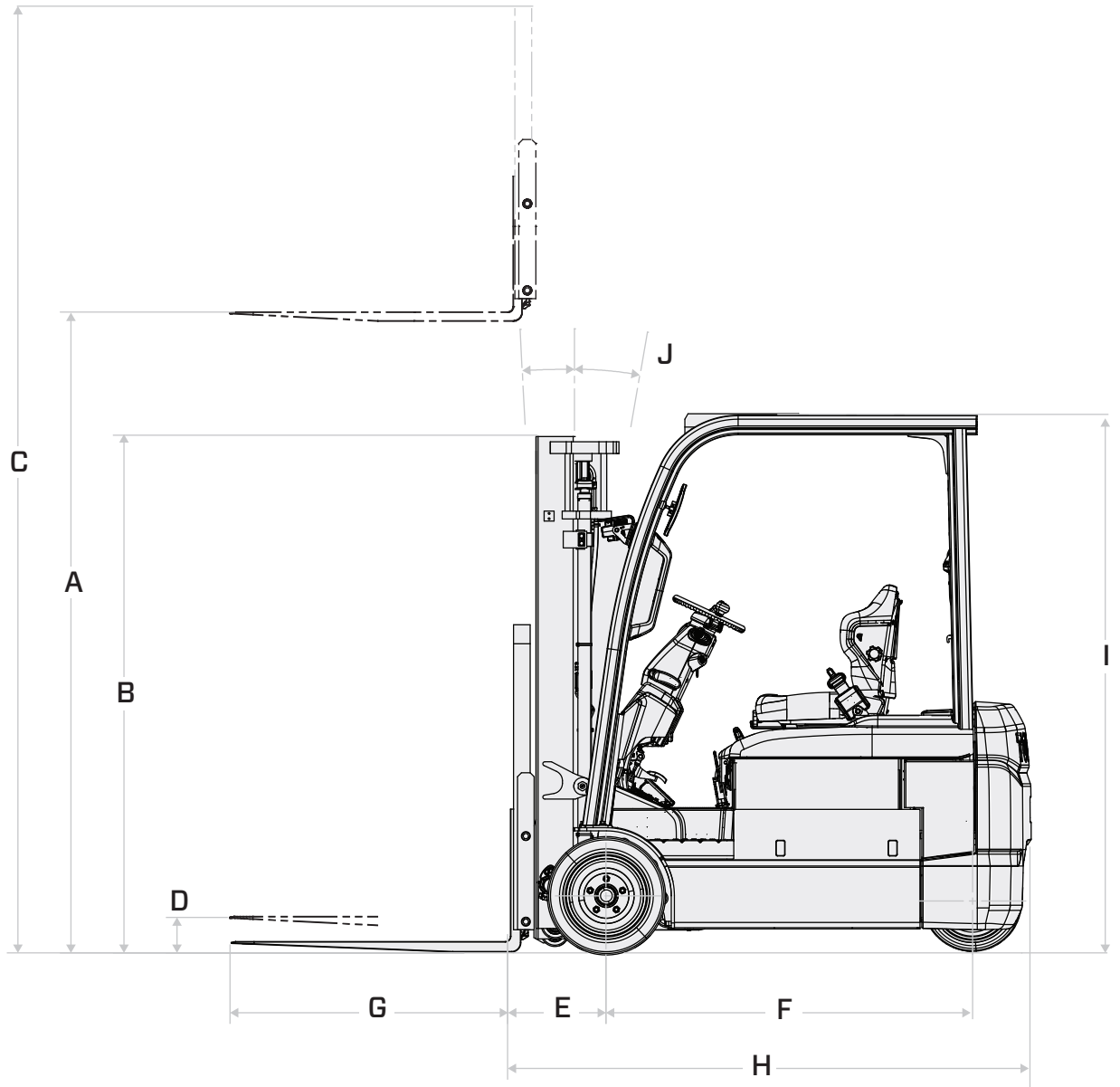

MAST SPECIFICATIONS

MAST TYPE	MAXIMUM FORK HEIGHT (TOP OF FORKS)	OVERALL HEIGHT			FREE-LIFT		TILT RANGE		LOAD CAPACITY AT 24 IN. (610 MM) LOAD CENTER ¹		
		LOWERED	EXTENDED		WITHOUT LOAD BACKREST	WITH STANDARD LOAD BACKREST	FWD	BWD	CUSHION	SOLID PN	AIR-FILLED PN
			WITHOUT LOAD BACKREST	WITH STANDARD LOAD BACKREST							
8FBE15U											
Wide Visible (V)	100 (2535)	67.7 (1720)	122.2 (3105)	147.8 (3755)	5.7 (145)	5.7 (145)	5	5	3000 (1360)	3000 (1360)	3000 (1360)
	107.5 (2735)	71.7 (1820)	130.1 (3305)	155.7 (3955)	5.7 (145)	5.7 (145)	5	6.5	3000 (1360)	3000 (1360)	3000 (1360)
	119 (3035)	77.6 (1970)	141.9 (3605)	167.5 (4255)	5.7 (145)	5.7 (145)	5	6.5	3000 (1360)	3000 (1360)	3000 (1360)
	131 (3335)	83.5 (2120)	153.7 (3905)	179.3 (4555)	5.7 (145)	5.7 (145)	5	6.5	3000 (1360)	3000 (1360)	3000 (1360)
	139 (3535)	87.4 (2220)	161.6 (4105)	187.2 (4755)	5.7 (145)	5.7 (145)	5	6.5	3000 (1360)	3000 (1360)	3000 (1360)
	147 (3735)	93.7 (2380)	169.5 (4305)	195.1 (4955)	5.7 (145)	5.7 (145)	5	6.5	3000 (1360)	3000 (1360)	3000 (1360)
Full Free-Lift 2-Stage (FV)	158.5 (4035)	101.2 (2570)	181.3 (4605)	206.9 (5255)	5.7 (145)	5.7 (145)	5	6.5	3000 (1360)	2900 (1315)	2870 (1301)
	107.5 (2735)	71.7 (1820)	129.1 (3280)	155.7 (3955)	50.2 (1275)	23.6 (600)	5	6.5	3000 (1360)	3000 (1360)	3000 (1360)
	119 (3035)	77.6 (1970)	140.9 (3580)	167.5 (4255)	56.1 (1425)	29.5 (750)	5	6.5	3000 (1360)	3000 (1360)	3000 (1360)
	131 (3335)	83.5 (2120)	152.8 (3880)	179.3 (4555)	62 (1575)	35.4 (900)	5	6.5	3000 (1360)	3000 (1360)	3000 (1360)
	139 (3535)	87.4 (2220)	160.6 (4080)	187.2 (4755)	65.9 (1675)	39.4 (1000)	5	6.5	3000 (1360)	3000 (1360)	3000 (1360)
	147 (3735)	93.7 (2380)	168.5 (4280)	195.1 (4955)	72.2 (1835)	45.7 (1160)	5	6.5	3000 (1360)	3000 (1360)	3000 (1360)
Full Free-Lift 3-Stage (FSV)	158.5 (4035)	101.2 (2570)	180.3 (4580)	206.9 (5255)	79.7 (2025)	53.1 (1350)	5	6.5	3000 (1360)	2900 (1315)	2870 (1301)
	147 (3735)	69.7 (1770)	168.3 (4275)	195.1 (4955)	48.4 (1230)	21.7 (550)	5	6.5	3000 (1360)	3000 (1360)	3000 (1360)
	158.5 (4035)	73.6 (1870)	180.1 (4575)	206.9 (5255)	52.4 (1330)	25.6 (650)	5	6.5	3000 (1360)	2800 (1270)	2800 (1270)
	170.5 (4335)	77.6 (1970)	191.9 (4875)	218.7 (5555)	56.3 (1430)	29.5 (750)	5	6.5	2900 (1315)	2800 (1270)	2800 (1270)
	189 (4800)	83.5 (2120)	209.6 (5325)	236.4 (6005)	62.2 (1580)	35.4 (900)	5	6.5	2800 (1270)	2700 (1224)	2700 (1224)
	198 (5035)	87.4 (2220)	219.5 (5575)	246.3 (6255)	66.1 (1680)	39.4 (1000)	5	6.5	2800 (1270)	2450 (1111)	2400 (1088)
Full Free-Lift 4-Stage (QFV)	217.5 (5535)	93.7 (2380)	239.2 (6075)	265.9 (6755)	72.4 (1840)	45.7 (1160)	5	6.5	2400 (1088)	1840 (834)	1790 (811)
	237.5 (6035)	101.2 (2570)	258.9 (6575)	285.6 (7255)	79.9 (2030)	53.1 (1350)	5	6.5	2000 (907)	1440 (653) ¹	1390 (630) ¹
	241.3 (6130)	83.5 (2120)	262.6 (6670)	289.4 (7350)	62.2 (1580)	35.4 (900)	5	3	2200 (998)	1760 (798)	1710 (775)
	259.4 (6590)	89.4 (2270)	281.3 (7145)	307.5 (7810)	68.1 (1730)	41.3 (1050)	5	3	2100 (952)	1650 (748)	1600 (725)
	277.5 (7050)	95.7 (2430)	299.4 (7605)	325.6 (8270)	74.4 (1890)	47.6 (1210)	5	3	1600 (725)	1250 (567) ¹	1200 (544) ¹

MAST TYPE	MAXIMUM FORK HEIGHT (TOP OF FORKS)	OVERALL HEIGHT			FREE-LIFT		TILT RANGE		LOAD CAPACITY AT 24 IN. (610 MM) LOAD CENTER ¹		
		LOWERED	EXTENDED		WITHOUT LOAD BACKREST	WITH STANDARD LOAD BACKREST	FWD	BWD	CUSHION	SOLID PN	AIR-FILLED PN
			WITHOUT LOAD BACKREST	WITH STANDARD LOAD BACKREST							
8FBES15U											
Wide Visible (V)	100 (2535)	67.7 (1720)	122.2 (3105)	147.8 (3755)	5.7 (145)	5.7 (145)	5	5	3000 (1360)	3000 (1360)	3000 (1360)
	107.5 (2735)	71.7 (1820)	130.1 (3305)	155.7 (3955)	5.7 (145)	5.7 (145)	5	6.5	3000 (1360)	3000 (1360)	3000 (1360)
	119 (3035)	77.6 (1970)	141.9 (3605)	167.5 (4255)	5.7 (145)	5.7 (145)	5	6.5	3000 (1360)	3000 (1360)	3000 (1360)
	131 (3335)	83.5 (2120)	153.7 (3905)	179.3 (4555)	5.7 (145)	5.7 (145)	5	6.5	3000 (1360)	3000 (1360)	3000 (1360)
	139 (3535)	87.4 (2220)	161.6 (4105)	187.2 (4755)	5.7 (145)	5.7 (145)	5	6.5	3000 (1360)	3000 (1360)	3000 (1360)
	147 (3735)	93.7 (2380)	169.5 (4305)	195.1 (4955)	5.7 (145)	5.7 (145)	5	6.5	3000 (1360)	3000 (1360)	3000 (1360)
Full Free-Lift 2-Stage (FV)	158.5 (4035)	101.2 (2570)	181.3 (4605)	206.9 (5255)	5.7 (145)	5.7 (145)	5	6.5	3000 (1360)	3000 (1360)	2950 (1338)
	107.5 (2735)	71.7 (1820)	129.1 (3280)	155.7 (3955)	50.2 (1275)	23.6 (600)	5	6.5	3000 (1360)	3000 (1360)	3000 (1360)
	119 (3035)	77.6 (1970)	140.9 (3580)	167.5 (4255)	56.1 (1425)	29.5 (750)	5	6.5	3000 (1360)	3000 (1360)	3000 (1360)
	131 (3335)	83.5 (2120)	152.8 (3880)	179.3 (4555)	62 (1575)	35.4 (900)	5	6.5	3000 (1360)	3000 (1360)	3000 (1360)
	139 (3535)	87.4 (2220)	160.6 (4080)	187.2 (4755)	65.9 (1675)	39.4 (1000)	5	6.5	3000 (1360)	3000 (1360)	3000 (1360)
	147 (3735)	93.7 (2380)	168.5 (4280)	195.1 (4955)	72.2 (1835)	45.7 (1160)	5	6.5	3000 (1360)	3000 (1360)	3000 (1360)
Full Free-Lift 3-Stage (FSV)	158.5 (4035)	101.2 (2570)	180.3 (4580)	206.9 (5255)	79.7 (2025)	53.1 (1350)	5	6.5	3000 (1360)	3000 (1360)	2950 (1338)
	147 (3735)	69.7 (1770)	168.3 (4275)	195.1 (4955)	48.4 (1230)	21.7 (550)	5	6.5	3000 (1360)	3000 (1360)	3000 (1360)
	158.5 (4035)	73.6 (1870)	180.1 (4575)	206.9 (5255)	52.4 (1330)	25.6 (650)	5	6.5	3000 (1360)	2900 (1315)	2900 (1315)
	170.5 (4335)	77.6 (1970)	191.9 (4875)	218.7 (5555)	56.3 (1430)	29.5 (750)	5	6.5	3000 (1360)	2840 (1288)	2840 (1288)
	189 (4800)	83.5 (2120)	209.6 (5325)	236.4 (6005)	62.2 (1580)	35.4 (900)	5	6.5	2900 (1315)	2740 (1242)	2740 (1242)
	198 (5035)	87.4 (2220)	219.5 (5575)	246.3 (6255)	66.1 (1680)	39.4 (1000)	5	6.5	2800 (1270)	2600 (1179)	2550 (1156)
Full Free-Lift 4-Stage (QFV)	217.5 (5535)	93.7 (2380)	239.2 (6075)	265.9 (6755)	72.4 (1840)	45.7 (1160)	5	6.5	2600 (1179)	1970 (893)	1920 (870)
	237.5 (6035)	101.2 (2570)	258.9 (6575)	285.6 (7255)	79.9 (2030)	53.1 (1350)	5	6.5	2300 (1043)	1450 (657) ¹	1400 (635) ¹
	241.3 (6130)	83.5 (2120)	262.6 (6670)	289.4 (7350)	62.2 (1580)	35.4 (900)	5	3	2220 (1006)	1820 (825)	1770 (802)
	259.4 (6590)	89.4 (2270)	281.3 (7145)	307.5 (7810)	68.1 (1730)	41.3 (1050)	5	3	2120 (961)	1700 (771)	1650 (748)
	277.5 (7050)	95.7 (2430)	299.4 (7605)	325.6 (8270)	74.4 (1890)	47.6 (1210)	5	3	1620 (734)	1270 (576) ¹	1240 (562) ¹

Note: Height of standard load backrest is 48".
¹ All capacities of 1,500 lbs. or less are subject to a secondary review & could be denied by Toyota.

MAST SPECIFICATIONS

MAST TYPE	MAXIMUM FORK HEIGHT (TOP OF FORKS)	OVERALL HEIGHT				FREE-LIFT		TILT RANGE		LOAD CAPACITY AT 24 IN. (610 MM) LOAD CENTER ¹		
		LOWERED	EXTENDED		WITHOUT LOAD BACKREST	WITH STANDARD LOAD BACKREST	FWD	BWD	CUSHION	SOLID PN	AIR-FILLED PN	
			WITHOUT LOAD BACKREST	WITH STANDARD LOAD BACKREST								deg
		in (mm)	in (mm)	in (mm)	in (mm)	in (mm)	in (mm)	deg	deg	lb (kg)	lb (kg)	lb (kg)
8FBEB18U												
Wide Visible (V)	100 (2535)	67.7 (1720)	122.2 (3105)	147.8 (3755)	5.7 (145)	5.7 (145)	5	5	3500 (1587)	3500 (1587)	3500 (1587)	
	107.5 (2735)	71.7 (1820)	130.1 (3305)	155.7 (3955)	5.7 (145)	5.7 (145)	5	6.5	3500 (1587)	3500 (1587)	3500 (1587)	
	119 (3035)	77.6 (1970)	141.9 (3605)	167.5 (4255)	5.7 (145)	5.7 (145)	5	6.5	3500 (1587)	3500 (1587)	3500 (1587)	
	131 (3335)	83.5 (2120)	153.7 (3905)	179.3 (4555)	5.7 (145)	5.7 (145)	5	6.5	3500 (1587)	3500 (1587)	3500 (1587)	
	139 (3535)	87.4 (2220)	161.6 (4105)	187.2 (4755)	5.7 (145)	5.7 (145)	5	6.5	3500 (1587)	3500 (1587)	3500 (1587)	
	147 (3735)	93.7 (2380)	169.5 (4305)	195.1 (4955)	5.7 (145)	5.7 (145)	5	6.5	3500 (1587)	3500 (1587)	3500 (1587)	
Full Free-Lift 2-Stage (FV)	158.5 (4035)	101.2 (2570)	181.3 (4605)	206.9 (5255)	5.7 (145)	5.7 (145)	5	6.5	3400 (1542)	3400 (1542)	3400 (1542)	
	107.5 (2735)	71.7 (1820)	129.1 (3280)	155.7 (3955)	50.2 (1275)	23.6 (600)	5	6.5	3500 (1587)	3500 (1587)	3500 (1587)	
	119 (3035)	77.6 (1970)	140.9 (3580)	167.5 (4255)	56.1 (1425)	29.5 (750)	5	6.5	3500 (1587)	3500 (1587)	3500 (1587)	
	131 (3335)	83.5 (2120)	152.8 (3880)	179.3 (4555)	62 (1575)	35.4 (900)	5	6.5	3500 (1587)	3500 (1587)	3500 (1587)	
	139 (3535)	87.4 (2220)	160.6 (4080)	187.2 (4755)	65.9 (1675)	39.4 (1000)	5	6.5	3500 (1587)	3500 (1587)	3500 (1587)	
	147 (3735)	93.7 (2380)	168.5 (4280)	195.1 (4955)	72.2 (1835)	45.7 (1160)	5	6.5	3500 (1587)	3500 (1587)	3500 (1587)	
Full Free-Lift 3-Stage (FSV)	158.5 (4035)	101.2 (2570)	180.3 (4580)	206.9 (5255)	79.7 (2025)	53.1 (1350)	5	6.5	3400 (1542)	3400 (1542)	3400 (1542)	
	147 (3735)	69.7 (1770)	168.3 (4275)	195.1 (4955)	48.4 (1230)	21.7 (550)	5	6.5	3400 (1542)	3200 (1451)	3200 (1451)	
	158.5 (4035)	73.6 (1870)	180.1 (4575)	206.9 (5255)	52.4 (1330)	25.6 (650)	5	6.5	3300 (1496)	3200 (1451)	3200 (1451)	
	170.5 (4335)	77.6 (1970)	191.9 (4875)	218.7 (5555)	56.3 (1430)	29.5 (750)	5	6.5	3200 (1451)	3100 (1406)	3100 (1406)	
	189 (4800)	83.5 (2120)	209.6 (5325)	236.4 (6005)	62.2 (1580)	35.4 (900)	5	6.5	3100 (1406)	2800 (1270)	2800 (1270)	
	198 (5035)	87.4 (2220)	219.5 (5575)	246.3 (6255)	66.1 (1680)	39.4 (1000)	5	6.5	2900 (1315)	2630 (1192)	2580 (1170)	
Full Free-Lift 4-Stage (QFV)	217.5 (5535)	93.7 (2380)	239.2 (6075)	265.9 (6755)	72.4 (1840)	45.7 (1160)	5	6.5	2580 (1170)	1920 (870)	1870 (848)	
	237.5 (6035)	101.2 (2570)	258.9 (6575)	285.6 (7255)	79.9 (2030)	53.1 (1350)	5	6.5	2070 (938)	1530 (694) ¹	480 (671) ¹	
	241.3 (6130)	83.5 (2120)	262.6 (6670)	289.4 (7350)	62.2 (1580)	35.4 (900)	5	3	2400 (1089)	1920 (870)	1870 (848)	
	259.4 (6590)	89.4 (2270)	281.3 (7145)	307.5 (7810)	68.1 (1730)	41.3 (1050)	5	3	2300 (1043)	1830 (830)	1680 (807)	
	277.5 (7050)	95.7 (2430)	299.4 (7605)	325.6 (8270)	74.4 (1890)	47.6 (1210)	5	3	1700 (771)	1350 (612) ¹	1300 (589) ¹	

MAST TYPE	MAXIMUM FORK HEIGHT (TOP OF FORKS)	OVERALL HEIGHT				FREE-LIFT		TILT RANGE		LOAD CAPACITY AT 24 IN. (610 MM) LOAD CENTER ¹		
		LOWERED	EXTENDED		WITHOUT LOAD BACKREST	WITH STANDARD LOAD BACKREST	FWD	BWD	CUSHION	SOLID PN	AIR-FILLED PN	
			WITHOUT LOAD BACKREST	WITH STANDARD LOAD BACKREST								deg
		in (mm)	in (mm)	in (mm)	in (mm)	in (mm)	in (mm)	deg	deg	lb (kg)	lb (kg)	lb (kg)
8FBEB18U												
Wide Visible (V)	100 (2535)	67.7 (1720)	122.2 (3105)	147.8 (3755)	5.7 (145)	5.7 (145)	5	5	3500 (1587)	3500 (1587)	3500 (1587)	
	107.5 (2735)	71.7 (1820)	130.1 (3305)	155.7 (3955)	5.7 (145)	5.7 (145)	5	6.5	3500 (1587)	3500 (1587)	3500 (1587)	
	119 (3035)	77.6 (1970)	141.9 (3605)	167.5 (4255)	5.7 (145)	5.7 (145)	5	6.5	3500 (1587)	3500 (1587)	3500 (1587)	
	131 (3335)	83.5 (2120)	153.7 (3905)	179.3 (4555)	5.7 (145)	5.7 (145)	5	6.5	3500 (1587)	3500 (1587)	3500 (1587)	
	139 (3535)	87.4 (2220)	161.6 (4105)	187.2 (4755)	5.7 (145)	5.7 (145)	5	6.5	3500 (1587)	3500 (1587)	3500 (1587)	
	147 (3735)	93.7 (2380)	169.5 (4305)	195.1 (4955)	5.7 (145)	5.7 (145)	5	6.5	3500 (1587)	3500 (1587)	3500 (1587)	
Full Free-Lift 2-Stage (FV)	158.5 (4035)	101.2 (2570)	181.3 (4605)	206.9 (5255)	5.7 (145)	5.7 (145)	5	6.5	3400 (1542)	3400 (1542)	3400 (1542)	
	107.5 (2735)	71.7 (1820)	129.1 (3280)	155.7 (3955)	50.2 (1275)	23.6 (600)	5	6.5	3500 (1587)	3500 (1587)	3500 (1587)	
	119 (3035)	77.6 (1970)	140.9 (3580)	167.5 (4255)	56.1 (1425)	29.5 (750)	5	6.5	3500 (1587)	3500 (1587)	3500 (1587)	
	131 (3335)	83.5 (2120)	152.8 (3880)	179.3 (4555)	62 (1575)	35.4 (900)	5	6.5	3500 (1587)	3500 (1587)	3500 (1587)	
	139 (3535)	87.4 (2220)	160.6 (4080)	187.2 (4755)	65.9 (1675)	39.4 (1000)	5	6.5	3500 (1587)	3500 (1587)	3500 (1587)	
	147 (3735)	93.7 (2380)	168.5 (4280)	195.1 (4955)	72.2 (1835)	45.7 (1160)	5	6.5	3500 (1587)	3500 (1587)	3500 (1587)	
Full Free-Lift 3-Stage (FSV)	158.5 (4035)	101.2 (2570)	180.3 (4580)	206.9 (5255)	79.7 (2025)	53.1 (1350)	5	6.5	3400 (1542)	3400 (1542)	3400 (1542)	
	147 (3735)	69.7 (1770)	168.3 (4275)	195.1 (4955)	48.4 (1230)	21.7 (550)	5	6.5	3400 (1542)	3200 (1451)	3200 (1451)	
	158.5 (4035)	73.6 (1870)	180.1 (4575)	206.9 (5255)	52.4 (1330)	25.6 (650)	5	6.5	3300 (1496)	3200 (1451)	3200 (1451)	
	170.5 (4335)	77.6 (1970)	191.9 (4875)	218.7 (5555)	56.3 (1430)	29.5 (750)	5	6.5	3200 (1451)	3100 (1406)	3100 (1406)	
	189 (4800)	83.5 (2120)	209.6 (5325)	236.4 (6005)	62.2 (1580)	35.4 (900)	5	6.5	3100 (1406)	2800 (1270)	2800 (1270)	
	198 (5035)	87.4 (2220)	219.5 (5575)	246.3 (6255)	66.1 (1680)	39.4 (1000)	5	6.5	2900 (1315)	2630 (1192)	2580 (1170)	
Full Free-Lift 4-Stage (QFV)	217.5 (5535)	93.7 (2380)	239.2 (6075)	265.9 (6755)	72.4 (1840)	45.7 (1160)	5	6.5	2580 (1170)	1920 (870)	1870 (848)	
	237.5 (6035)	101.2 (2570)	258.9 (6575)	285.6 (7255)	79.9 (2030)	53.1 (1350)	5	6.5	2070 (938)	1530 (694) ¹	480 (671) ¹	
	241.3 (6130)	83.5 (2120)	262.6 (6670)	289.4 (7350)	62.2 (1580)	35.4 (900)	5	3	2400 (1089)	1920 (870)	1870 (848)	
	259.4 (6590)	89.4 (2270)	281.3 (7145)	307.5 (7810)	68.1 (1730)	41.3 (1050)	5	3	2300 (1043)	1830 (830)	1680 (807)	
	277.5 (7050)	95.7 (2430)	299.4 (7605)	325.6 (8270)	74.4 (1890)	47.6 (1210)	5	3	1700 (771)	1350 (612) ¹	1300 (589) ¹	

Note: Height of standard load backrest is 48".
¹ All capacities of 1,500 lbs. or less are subject to a secondary review & could be denied by Toyota.

MAST TYPE	MAXIMUM FORK HEIGHT (TOP OF FORKS)	OVERALL HEIGHT				FREE-LIFT		TILT RANGE		LOAD CAPACITY AT 24 IN. (610 MM) LOAD CENTER ¹	
		LOWERED	EXTENDED		WITHOUT LOAD BACKREST	WITH STANDARD LOAD BACKREST	FWD	BWD	CUSHION	SOLID PN	
			WITHOUT LOAD BACKREST	WITH STANDARD LOAD BACKREST							deg
8FBE20U											
Wide Visible (V)	100 (2540)	67.7 (1720)	122.2 (3105)	147.8 (3755)	5.9 (150)	5.9 (150)	5	5	4000 (1814)	3950 (1790)	
	108 (2740)	71.7 (1820)	130.1 (3305)	155.7 (3955)	5.9 (150)	5.9 (150)	5	6.5	4000 (1814)	3950 (1790)	
	119.5 (3040)	77.6 (1970)	141.9 (3605)	167.5 (4255)	5.9 (150)	5.9 (150)	5	6.5	4000 (1814)	3950 (1790)	
	131.5 (3340)	83.5 (2120)	153.7 (3905)	179.3 (4555)	5.9 (150)	5.9 (150)	5	6.5	4000 (1814)	3950 (1790)	
	139 (3540)	87.4 (2220)	161.6 (4105)	187.2 (4755)	5.9 (150)	5.9 (150)	5	6.5	4000 (1814)	3950 (1790)	
	147 (3740)	93.7 (2380)	169.5 (4305)	195.1 (4955)	5.9 (150)	5.9 (150)	5	6.5	4000 (1814)	3950 (1790)	
Full Free-Lift 2-Stage (FV)	159 (4040)	101.2 (2570)	181.3 (4605)	206.9 (5255)	5.9 (150)	5.9 (150)	5	6.5	4000 (1814)	3950 (1790)	
	108 (2740)	71.7 (1820)	129.1 (3280)	155.7 (3955)	50.4 (1280)	23.8 (605)	5	6.5	4000 (1814)	3950 (1790)	
	119.5 (3040)	77.6 (1970)	140.9 (3580)	167.5 (4255)	56.3 (1430)	29.7 (755)	5	6.5	4000 (1814)	3950 (1790)	
	131.5 (3340)	83.5 (2120)	152.8 (3880)	179.3 (4555)	62.2 (1580)	35.6 (905)	5	6.5	4000 (1814)	3950 (1790)	
	139 (3540)	87.4 (2220)	160.6 (4080)	187.2 (4755)	66.1 (1680)	39.6 (1005)	5	6.5	4000 (1814)	3950 (1790)	
Full Free-Lift 3-Stage (FSV)	147 (3740)	93.7 (2380)	168.5 (4280)	195.1 (4955)	72.4 (1840)	45.9 (1165)	5	6.5	4000 (1814)	3950 (1790)	
	159 (4040)	101.2 (2570)	180.3 (4580)	206.9 (5255)	79.9 (2030)	53.3 (1355)	5	6.5	4000 (1814)	3950 (1790)	
	147 (3740)	69.7 (1770)	168.3 (4275)	195.1 (4955)	48.6 (1235)	21.9 (555)	5	6.5	3950 (1791)	3750 (1700)	
	159 (4040)	73.6 (1870)	180.1 (4575)	206.9 (5255)	52.6 (1335)	25.8 (655)	5	6.5	3900 (1769)	3750 (1700)	
	170.5 (4340)	77.6 (1970)	191.9 (4875)	218.7 (5555)	56.5 (1435)	29.7 (755)	5	6.5	3850 (1740)	3680 (1670)	
	189 (4800)	83.5 (2120)	209.6 (5325)	236.4 (6005)	62.4 (1585)	35.6 (905)	5	6.5	3750 (1700)	3370 (1530)	
	198 (5040)	87.4 (2220)	219.5 (5575)	246.3 (6255)	66.3 (1685)	39.6 (1005)	5	6.5	3500 (1587)	2980 (1350)	
Full Free-Lift 4-Stage (QFV)	218 (5540)	93.7 (2380)	239.2 (6075)	265.9 (6755)	72.6 (1845)	45.9 (1165)	5	6.5	3300 (1496)	2490 (1130)	
	237.5 (6040)	101.2 (2570)	258.9 (6575)	285.6 (7255)	80.1 (2035)	53.3 (1355)	5	6.5	2550 (1156)	1790 (810)	
	241.5 (6135)	83.5 (2120)	262.6 (6670)	289.4 (7350)	62.4 (1585)	35.6 (905)	5	3	2800 (1270)	2250 (1020)	
Full Free-Lift 4-Stage (QFV)	259.6 (6595)	89.4 (2270)	281.3 (7145)	307.5 (7810)	68.3 (1735)	41.5 (1055)	5	3	2550 (1157)	1990 (900)	
	277.5 (7055)	95.7 (2430)	299.4 (7605)	325.6 (8270)	74.6 (1895)	47.8 (1215)	5	3	1850 (839)	1410 (640) ¹	

Note: Height of standard load backrest is 48".

¹ All capacities of 1,500 lbs. or less are subject to a secondary review & could be denied by Toyota.



“I’M HERE TO MAKE SURE YOUR FORKLIFTS DON’T TAKE VACATION DAYS.”

Butch – 360 Technician, ProLift, Cincinnati, Ohio



HELP IS ALWAYS HERE WITH TOYOTA 360 SUPPORT.

The industry’s best and most comprehensive dealer network quickly delivers Toyota Certified Technicians to your work site. These specially trained technicians can also help assess your warehouse and facility needs to recommend the right equipment for the job. And with the largest fleet of material handling equipment, Toyota 360 keeps your business running at full speed.

ToyotaForklift.com/360-Support



YOUR BUSINESS IS RIDING ON IT.

Some product features described herein are optional. Please consult your dealer for specifications. Details of specifications and equipment are based on information available at time of printing and may change without notice. Photos may not reflect physical trucks.

