

WALKIE REACH STACKER



3000 LBS.

SPECIFICATIONS



WS1-RE30

CLASS
3

ELECTRIC PALLET JACKS | STACKERS | TOW TRACTORS

ToyotaForklift.com

WALKIE REACH STACKER

CAPACITY
3000 LBS.

WHEELBASE
55.1

LOAD CENTER
24 IN.

INDUSTRIES



General
Manufacturing



General
Warehousing



Cold Storage



Food Storage



Beverage



Retail

STANDARD FEATURES

PERFORMANCE

- 24 Volt Electrical System
- SB-175 Red Connector
- On/Off Key Switch
- UL Type-E Constructed
- AC Drive Motor
- Cushioned Mast Stops
- Electric Raise And Lower Controls In Operator Handle

BODY/EXTERIOR DESIGN

- Electric Horn
- 30 Inch Wide ITA Class II Hook Type Carriage
- 42 Inch Long Pallet Forks
- 48 Inch High Load Back Rest Extension
- Rubber Drive Tire
- Tandem Polyurethane Load Wheels 4" dia. x 2.875"
- Battery Compartment: 32.13" x 13.31" x Open Height (Steel-to-Steel)
- 32" to 50" Base Leg Openings in 1" increments
- Carriage Tilt 3o Forward/4o Backward
- Easy Access Service Cover
- Fixed Baselegs

OPERABILITY & ERGONOMICS

- Emergency Power Disconnect Switch
- Battery Discharge Indicator w/ Lift Interrupt and Hour Meter
- Regenerative Plugging
- Ergonomically Advanced Control Handle
- Polycarbonate Mast Guard
- Dual Thumb Wheel Control Forward and Reverse
- Direction and Travel Speed
- Power On Self Test

Please contact your local, authorized Toyota Dealer for a complete list of available options.

OPTIONAL EQUIPMENT

LOAD HANDLING

- Fork Length, 30"
- Fork Length, 36"
- Fork Length, 48"
- Sideshift Carriage
- 36" Reduced Height Load Backrest Extension
- 44" Reduced Height Load Backrest Extension
- Power Steering
- Greasable Steer Bearing

LIGHTS, INDICATORS & SAFETY

- Screen Guard In Place Of Safety Glass Mast Guard
- Red Flashing Light
- Amber Flashing Light
- Blue Flashing Light
- Electronic Travel Alarm (Forward & Reverse)
- Electronic Travel Alarm (Forward Only)
- Electronic Travel Alarm (Reverse Only)
- Non-Rubber Static Strap

BODY

- Battery Compartment Rollers with Dual Sidegates
- Pallet Centering Guide
- Magnetic Storage Tray
- Storage Tray, Battery Compartment Mounted
- Large Magnetic Storage Tray, Battery Compartment Mounted
- Battery Gate Interlock
- Single Tier Accessory Bar
- LED Work Light
- Operator Fan
- Power Hook-Up Onboard Terminal (10 Ah)
- Non-Powered Accessory Bar
- Electronic PIN Code Pad
- Keyless On/Off Switch in lieu of Key Switch

BATTERY ACCESSORIES

- Non - Standard Battery Connector (Color Yellow)
- Non - Standard Battery Connector (Color Gray)
- Non - Standard Battery Connector (Color Blue)
- Toyota LiB ESS Tag
- CAN-COM and ESS Tag for Toyota LiB

WHEELS & TIRES

- Drive Tire Crowned Poly
- Drive Tire Non-Marking Rubber White
- Drive Tire Poly
- Drive Tire Poly Razor Sipe
- Drive Tire "Smoothy" Poly
- Drive Tire Dyalon B Poly
- Drive Tire Poly Center Groove
- Drive Tire Diamond

SPECIAL MODELS

- UL Type "E"
- UL Type "EE"
- Bilingual Decals
- Export Preparation Package
- Corrosion Conditioning
- Cold Storage Conditioning (Includes Corrosion Protection Conditioning)
- Aux. Hydraulic Function Valve & Hosing W/ Carriage Mounted Termination

Please contact your local, authorized Toyota Dealer for a complete list of available options.

TRUCK SPECIFICATIONS

GENERAL DATA			MODEL NUMBERS	
			WS1-RE30	
Load Capacity	lb (kg)		3000 (1361)	
Load Center	in (mm)		24 (600)	
Power Type			Battery	
Operator Position			Walkie	
Tire Type	Drive / Caster / Load		Rubber/Polyurethane	
Wheels (x = driven)	Drive / Caster / Load		1x / 2 / 4	
EXTERIOR DIMENSIONS			WS1-RE30	
A Maximum Fork Height (MFH)	in (mm)		189 (4800)	
B Free Lift	in (mm)		6 (153)	
C Fork Size (T x W x L)	in (mm)		1.75 x 4 x 42 (45 x 100 x 1067)	
D Fork Adjustment (Minimum/Maximum)	in (mm)		10 (254) / 31 (787)	
E Tilt Range (Mast Tilt) (Forward/Backward)	degree		3/4	
F Head Length (Length to Fork Face)	in (mm)		47.9 (1217)	
G Truck Length (Length to end of base legs)	in (mm)		69.7 (1770)	
H Fork Lowered Height	in (mm)		2 (51)	
I Mast Lowered Height	in (mm)		83 (2108)	
J Base Leg Inside Dimension (ID) - 1" increments	in (mm)		32 to 50 (813 to 1270)	
K Base Leg Outside Dimension (OD) -1" increments	in (mm)		40 to 58 (1016 to 1473)	
L Power Unit Width	in (mm)		32.5 (826)	
M Power Unit Height	in (mm)		34 (864)	
N Turning Radius	in (mm)		65 (1651)	
O Base Leg Width	in (mm)		4 (101)	
P Underclearance (Center of Wheelbase)	in (mm)		2.1 (53)	
Q Battery Compartment (L x W x open height)	in (mm)		32.13 x 13.31 (816 x 338)	
R Wheelbase	in (mm)		55.1 (1400)	
S Reach Stroke	in (mm)		24 (610)	
Mast Extended Height	in (mm)		172 (4369)	
Fork Carriage Width (ITA Hook-Type)	in (mm)		30 (762)	
Sideshift, Optional (Each Way) ³	in (mm)		2 or 3 (51 or 76)	
Basic Right Angle Stacking Aisle Width ¹			See Chart	
PERFORMANCE DATA			WS1-RE30	
Speeds	Maximum Travel	Full Load	mph (km/h)	3.5 (5.6)
		No Load	mph (km/h)	3.5 (5.6)
	Lifting	Full Load	fpm (mm/sec)	29 (147)
		No Load	fpm (mm/sec)	46 (234)
	Lowering	Full Load	fpm (mm/sec)	60 (305)
		No Load	fpm (mm/sec)	47 (239)
	Reach/Retract Time	Full Load	sec	4.0
		No Load	sec	4.0
	Tilt (Up/Down) Time	Full Load	sec	4.0
		No Load	sec	3.0
	Sideshift Time	Full Load	sec	2.5
		No Load	sec	2.5
	Gradeability ²	Loaded / Unloaded	%	6 / 10
	TRUCK WEIGHTS			WS1-RE30
Total Weight Without Battery	lb (kg)		3252 (1475) - 3909 (1773)	
TIRES			WS1-RE30	
Tire Size ² (dia. x width)	Drive	in (mm)	12 x 4.5 (305 x 114)	
	Load	in (mm)	4 x 2.875 (102 x 73)	
Grade Clearance		%	10	
Brake			Regenerative	
POWER SYSTEM			WS1-RE30	
Battery (6-hour rating)	Voltage / Capacity (maximum)	hp (kW)	24 (654)	
	Weight (minimum)	lb. (kg)	950 (431)	

1 Please refer to the Aisle Width Requirements for Right Angle Stacking charts.

2 Trucks are designed for level floor operation. Represents ability to transverse short ramps when required.

3 32 in. and 33 in. baseleg BLO have 2 in. each way. All other base-leg BLO have 3 in. each way.

EXTERIOR DIMENSIONS

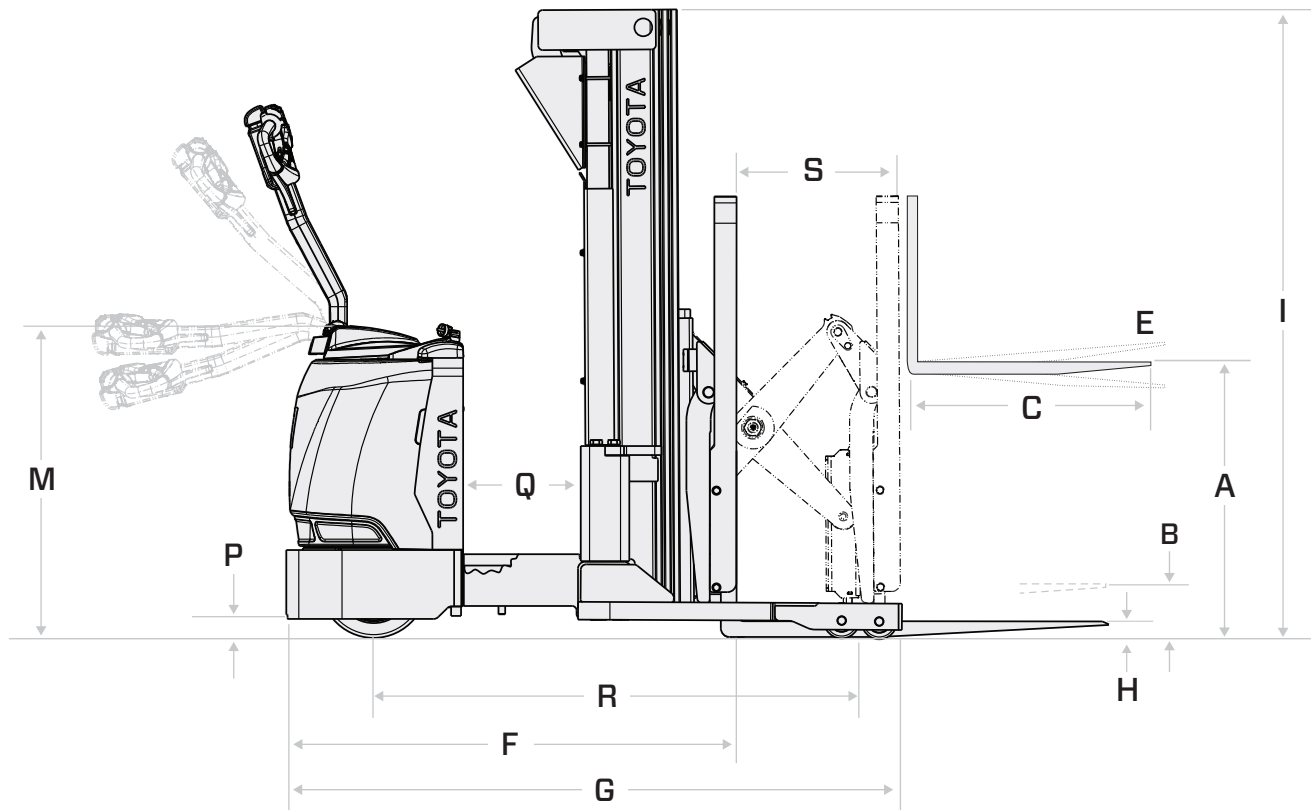
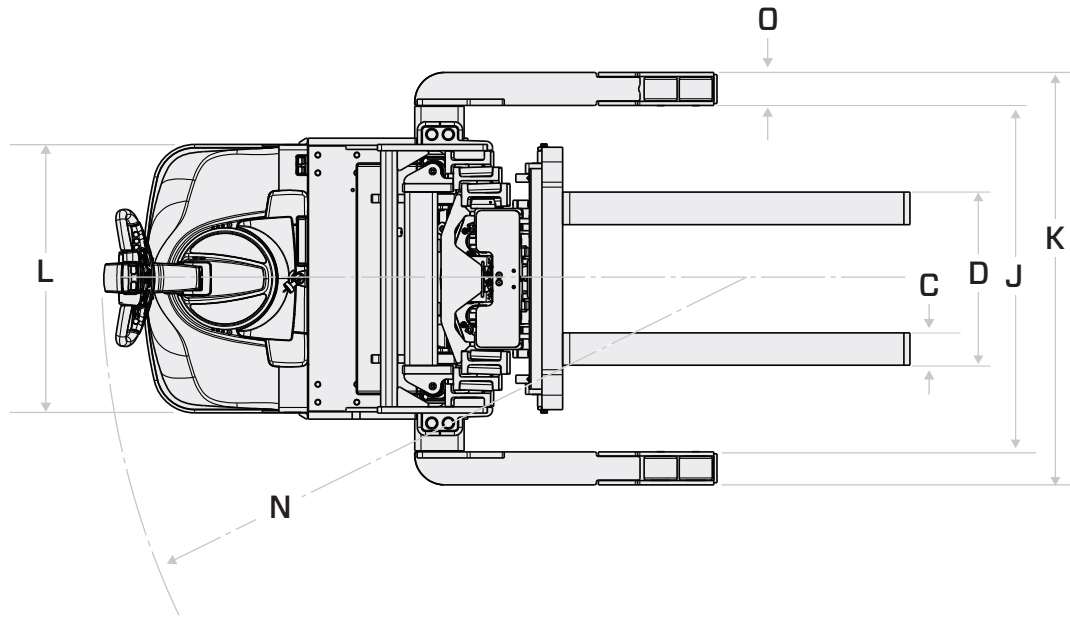

MAST SPECIFICATIONS

MAST TYPE	MAXIMUM FORK HEIGHT (TOP OF FORKS) in (mm)	OVERALL HEIGHT		FREE-LIFT ³ WITH STANDARD LOAD BACKREST in (mm)	TILT RANGE (CARRIAGE TILT)		TRUCK WEIGHT WITHOUT BATTERY ⁴
		LOWERED ¹ in (mm)	EXTENDED ²		FWD deg	BWD deg	
			WITH STANDARD LOAD BACKREST in (mm)				
WS1-HD22							
Wide Visible (V)	100 (2540)	71 (1804)	148 (3760)	6 (153)	3	4	3,252 (1475)
	124 (3149)	83 (2109)	172 (4369)	6 (153)	3	4	3,362 (1525)
	150 (3810)	95 (2413)	198 (5030)	6 (153)	3	4	3,472 (1575)
Full Free-Lift 3-Stage (FSV)	150 (3810)	71 (1804)	198 (5030)	23 (584)	3	4	3,630 (1646)
	180 (4572)	83 (2109)	228 (5792)	35 (889)	3	4	3,853 (1748)
	189 (4800)	87 (2210)	237 (6020)	47 (1194)	3	4	3,909 (1773)

- 1 Tolerance = +/-0.5 in. (+/-13mm).
- 2 Tolerance = +2.5/-0.5 in. (+64/-13 mm).
- 3 Tolerance = +/-1 in. (+/-25.4 mm).
- 4 Add 100 lb. (45.4 kg) with sideshift option.

RIGHT-ANGLE STACKING AISLE REQUIREMENTS

LOAD WIDTH	WS1-RE30	
	LOAD LENGTH	
	42 (1067)	48 (1219)
in (mm)	in (mm)	in (mm)
30 (762)	84 (2134)	92 (2337)
32 (813)	84 (2134)	91 (2311)
36 (914)	84 (2134)	91 (2311)
40 (1016)	83 (2108)	90 (2286)
42 (1067)	83 (2108)	90 (2286)
48 (1219)	81 (2057)	89 (2261)

Aisle width requirements are based on 6" (153 mm) clearance between each side of the load.
 Add a minimum of 6" to 10" (153 to 254 mm) for maneuverability.
 Add a minimum of 4" to 5" (102 to 127 mm) for 3-stage mast.
 Add 2.5 in (64 mm) when equipped with sideshift carriage





“THE NAME ON MY SHIRT SAYS TOYOTA, BUT I WORK FOR YOU.”

Alan - 360 Technician, Atlas Toyota Material Handling, Chicago, IL



HELP IS ALWAYS HERE WITH TOYOTA 360 SUPPORT.

The industry's best and most comprehensive dealer network quickly delivers Toyota Certified Technicians to your work site. These specially trained technicians can also help assess your warehouse and facility needs to recommend the right equipment for the job. And with the largest fleet of used and rental material handling products, Toyota 360 keeps your business running at full speed.

ToyotaForklift.com/360-Support



YOUR BUSINESS IS RIDING ON IT

Some product features described herein are optional. Please consult your dealer for specifications. Details of specifications and equipment are based on information available at time of printing and may change without notice. Photos may not reflect physical trucks.



WALKIEREACHSTACKERS

©2026 Toyota Material Handling, Inc.