

# SCISSOR LIFT

**AICHI**  
A TOYOTA INDUSTRIES COMPANY

19, 20, 26, & 32 FT. PLATFORM HEIGHTS

# YOUR TALL ACCESS PASS

- ▶ 500 - 1000 lb. Capacity
- ▶ 24V AC Drive Motors
- ▶ Zero Degree Inside Turn Radius



SV1930E | SV2032E | SV2632E | SV2646E | SV3246E



**MACHI**  
A TOYOTA INDUSTRIES COMPANY

**SV2632E**

ELION  
CORPORATION

# ACCESS GRANTED

**THE AICHI E-SERIES SCISSOR LIFT.** These machines are engineered to be durable and easy to use. They are loaded with features to tackle your unique tasks and keep your people and equipment working harder, longer. Their thoughtful engineering and versatility make these scissor lifts dependable solutions for access challenges in your facilities.

## AICHI SCISSOR LIFT ADVANTAGES

### AC DRIVE MOTOR:

BRUSHLESS MOTOR DESIGN REQUIRE LESS MAINTENANCE AND DELIVERS GREATER POWER AND LONGER BATTERY LIFE.

#### ▶ ZERO-DEGREE INSIDE TURNING RADIUS:

Tight turning makes operating the scissor lift intuitive and easy.

#### ▶ DURABLE CONSTRUCTION:

Heavy-gauge steel panels and powder-coated paint make the E-Series Scissor Lifts built to last.

#### ▶ PLATFORM EXTENSION:

Additional platform length allows operators to reach across fixed objects for greater accessibility and flexibility in completion of work.

#### ▶ TILT ALARM:

Alarm alerts operators to unsafe working conditions and limits platform movement until proper operation is restored.

### ANTI-ROLLBACK FUNCTION:

WHEN TOO STEEP A GRADE IS ENCOUNTERED, BRAKE IS APPLIED TO PREVENT THE LIFT FROM ROLLING BACK DOWN A RAMP WHILE IN USE.

#### ▶ FOLD-DOWN GUARDRAILS:

Folding guardrails allow larger scissor lifts to pass through doorways and other low obstacles. Easy to use function utilizes snap-lock pins for simple manipulation by operators. *(Option on SV1930E model)*

#### ▶ DUAL OPERATIONAL MODES:

Available on the SV2632 and SV3246 models, high-capacity mode provides increased platform capacity at lower heights for flexible use of the scissor lift in multiple work settings.

#### ▶ UPPER CONTROL BOX:

Upper platform control box offers two mounting positions or remote use when operator is off of the scissor lift. Horn, battery discharge, and tilt alarm indicators ensure easy operator use.

# TALL, ORANGE, AND HANDY

## UNIQUE SOLUTIONS FOR UNIQUE CHALLENGES.

With five models offering working heights from 25 feet up to 38 feet, AICHI E-Series Scissor Lifts provide the access you need to complete your toughest jobs.

UP TO  
**38** FT.  
WORKING HEIGHT



EXTENDS UP TO 19 FEET



EXTENDS UP TO 26 FEET



EXTENDS UP TO 32 FEET

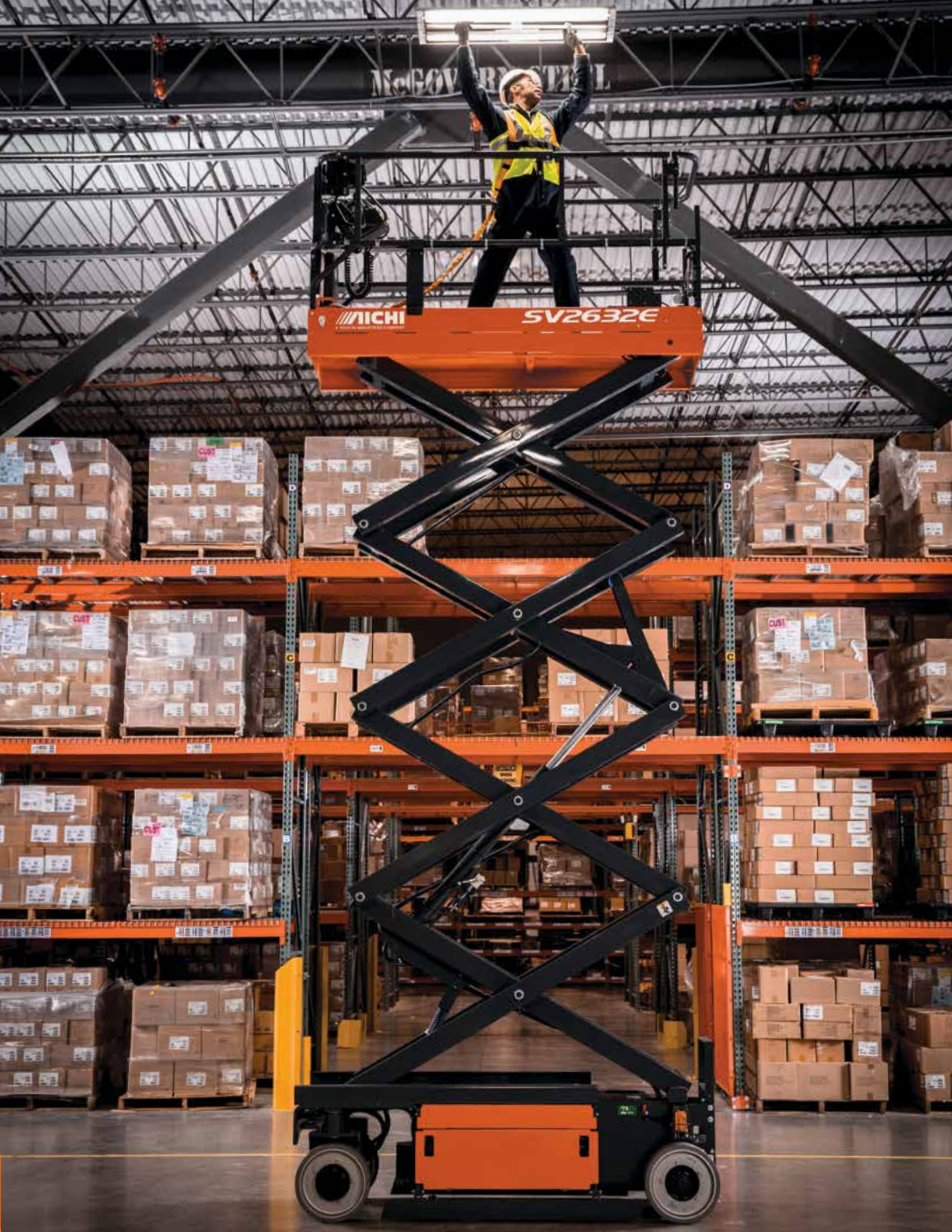



# EXTEND YOUR REACH

---

## ROLL-OUT PLATFORM EXTENSION DECK

This standard feature makes it easy to reach across objects on all AICHI E-Series Scissor Lift models. The extension adds a minimum of 35.4 inches to your working space with up to 50 inches of additional reach on larger models. The extension platform is easy to use, controlled with user-friendly handles that lock into place for secure operation.

UP TO **50** IN.  
ADDITIONAL WORKING SPACE



# OPENING DOORS

## ACCESS TO INTERIOR AREAS

is a pivotal function of the AICHI E-Series Scissor Lifts. The 1930E, our smallest and most nimble model, can fit through a standard doorway of 80"x32" with its fixed guardrails, making it a powerful ally for your facility maintenance needs. Our larger models feature standard fold-down guardrails and a thoughtful design of the detachable control box and cable, so you can adapt to your working space.

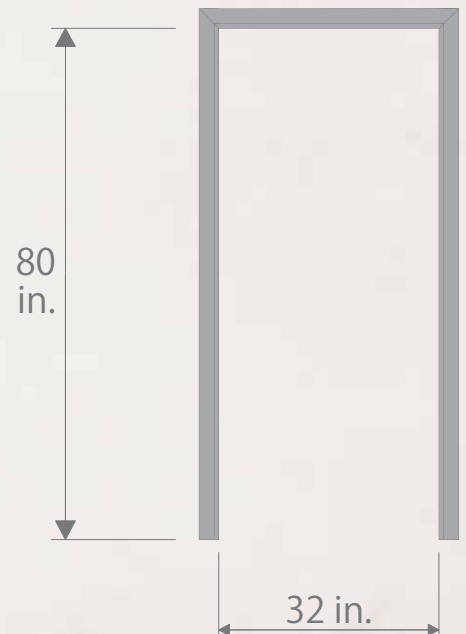

# AICHI SCISSOR LIFT

PLATFORM WORKING HEIGHT  
**25-38 FT.**

MOTOR  
**24V**

TURN RADIUS  
**0°**

## INDUSTRIES



Construction



General Warehousing



Retail



Facility Maintenance



General Manufacturing

## STANDARD FEATURES

### PERFORMANCE

- 24 volt AC drive system
- Improved running time over DC or hydraulic drive motors
- Full 90 degree steering angle
- Zero degree inside turning radius
- Anti-rollback function
- Roll-out platform extension deck
- 25% gradeability
- Reduced speed with platform elevated
- Toyota motor controllers with CAN-bus communication
- Proportional drive control
- Controlled descent function
- Dual operational modes provide increased platform capacity at lower lift heights (SV2632 and SV3246 models only)

### BODY/EXTERIOR DESIGN

- Tilt alarm with drive & lift cut out
- Pothole protection system
- Horn & travel alarm
- Solid non-marking tires
- Steel construction on all panels
- Fold-down guardrails with drywall gate<sup>2</sup> (optional on SV1930E model)
- 110V AC power to platform
- Lanyard attachment points (3)
- Forklift pockets
- Machine tie downs (front and back)
- Chain entrance protection
- Powder-coated paint
- Nickel plated scissor stack pins
- Upper control box with:
  - Joystick control with steering switch
  - Tilt alarm indicator light
  - Horn
  - Battery discharge indicator
  - Detachable coil type control cable
  - Dual mounting locations
  - Remote off-truck operation capability

### SERVICEABILITY

- Brushless AC drive motors
- High-efficiency battery charger
- Cord error indicator
- Scissor maintenance prop
- LCD multi-function display with:
  - Battery discharge indicator
  - Hour meter
  - Error code display
  - Battery charging status indicators
- Four 6 volt, 225AH deep cycle batteries
- Digital monitor w/ on-board tuning
- Hour meter
- Lubrication free bushings
- Slide-out battery trays for ease of access

## OPTIONAL EQUIPMENT

- Spring loaded half-height gate
- Panel carrier<sup>1</sup>
- Fold down guard rails with drywall gate<sup>2</sup>
- AC inverter (1000W)
- Tool tray
- LED strobe light (amber)
- Air line to platform
- Fire extinguisher bracket
- LED work lights

## CANADIAN SPECIFICATIONS<sup>1</sup>

- Load-sensing limit alert
- Dual flashing beacons
- Spring-loaded gate

<sup>1</sup> Not available on SV1930E model

<sup>2</sup> Standard on SV2032E, SV2632E, SV2646E, and SV3246E models

<sup>3</sup> Function speeds and gradeability assume there is one person on the platform and the battery is fully charged

<sup>4</sup> Travel speed and gradeability are subject to surface conditions and sufficient traction

<sup>5</sup> Weight information is approximate and does not take into account different option configurations or special designs

Please contact your local, authorized Toyota Dealer for a complete list of available options.

# EXTERIOR DIMENSIONS

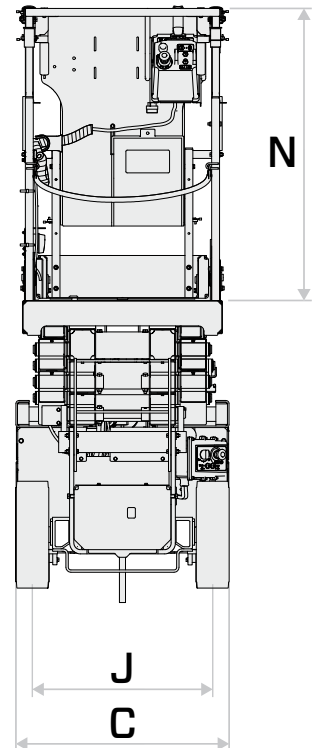
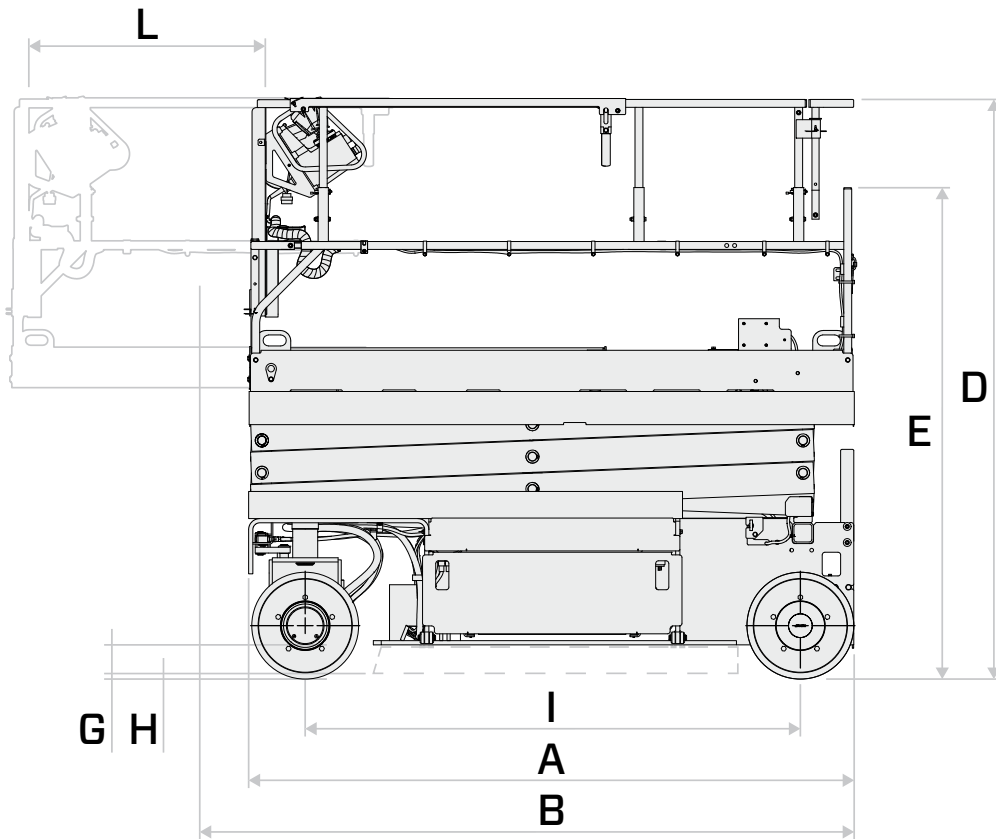
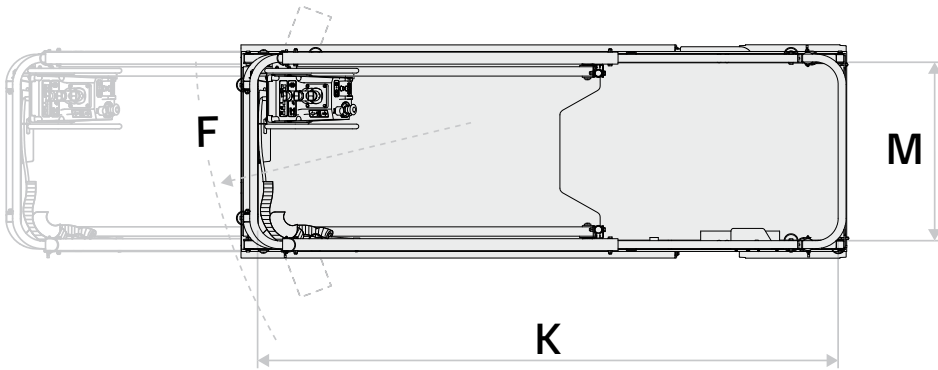

**LIFT SPECIFICATIONS**

DIMENSIONS AND WEIGHT			MODEL NUMBERS			
			SV1930E	SV1932E	SV2032E	
<b>A</b>	Overall Length	ft in (m)	6' 1.6" (1.87)	6' 1.6" (1.87)	7' 6.6" (2.3)	
<b>B</b>	Overall Length with Fold-down Guardrails Folded	ft in (m)	6' 9.1" (2.06)	6' 9.1" (2.06)	8' 2" (2.49)	
<b>C</b>	Overall Width	in (cm)	29.9 (76)	32.1 (81)	31.9 (81)	
<b>D</b>	Overall Height	ft in (m)	6' 6.3" (1.99)	6' 6.3" (1.99)	7' 2.7" (2.20)	
<b>E</b>	Overall Height with Fold-down Guardrails Folded	ft in (m)	5' 6" (1.65)	5' 6" (1.65)	6' 1.3" (1.87)	
	Vehicle Weight US/CA <sup>5</sup>	lb (kg)	2712 (1230) / -	- / 3395 (1540)	3616 (1640) / 4332 (1965)	
	Turning Radius (Inside)	deg	0 deg	0 deg	0 deg	
<b>F</b>	Turning Radius (Outside)	in (m)	73.6 (1.87)	73.6 (1.87)	88.5 (2.25)	
<b>G</b>	Ground Clearance (Center of Wheelbase)	in (cm)	5.1 (13)	5.1 (13)	5.1 (13)	
<b>H</b>	Ground Clearance (w/ Pothole Protectors Deployed)	in (cm)	0.787 (2)	0.787 (2)	0.787 (2)	
<b>I</b>	Wheelbase	in (m)	59.4 (1.51)	59.4 (1.51)	73.9 (1.88)	
	Ground Bearing Pressure	psi	109	109	81	
	Tire Size (Diameter x Width)	in (cm)	12.7x3.9 (32.3x10)	12.7x3.9 (32.3x10)	16x4.9 (40.6x12.5)	
<b>J</b>	Tread (Front and Rear)	in (cm)	26.0 (66)	26.0 (66)	26.9 (68.5)	
PLATFORM			SV1930E	SV1932E	SV2032E	
	Platform Capacity at Lift Height	lb at in (kg at m)	500 @ 228 (227 @ 5.7)	500 @ 228 (227 @ 5.7)	800 @ 240 (363 @ 6.1)	
	Platform Extension Capacity	lb (kg)	250 (113)	250 (113)	250 (113)	
	Platform Working Height	ft (m)	25 (7.62)	25 (7.62)	26 (7.92)	
	Platform Height	Lowered	in (m)	34.6 (0.88)	34.6 (0.88)	43.1 (1.1)
		Elevated	ft (m)	19 (5.7)	19 (5.7)	20 (6.1)
<b>K</b>	Platform Inner Length	in (cm)	69.7 (177)	69.7 (177)	86.7 (220)	
<b>L</b>	Platform Extension Length	in (cm)	35.4 (90)	35.4 (90)	35.4 (90)	
<b>M</b>	Platform Inner Width	in (cm)	26.8 (68)	26.8 (68)	26.8 (68)	
<b>N</b>	Platform Railing Height	in (cm)	43.7 (111)	43.7 (111)	43.7 (111)	
	Scissor Link Stages	#	3	3	3	
PERFORMANCE			SV1930E	SV1932E	SV2032E	
	Platform Lift/Lower Time	sec	26/30	26/30	28/40	
	Max Travel Speed <sup>3,4</sup>	Lowered	mph (km/h)	3.0 (4.8)	3.0 (4.8)	2.8 (4.5)
		Elevated	mph (km/h)	0.5 (0.8)	0.5 (0.8)	0.5 (0.8)
	Voltage	V	24	24	24	
	Drive System		Brushless Dual AC Motors	Brushless Dual AC Motors	Brushless Dual AC Motors	
	Gradeability <sup>3,4</sup>	deg (%)	14° (25%)	14° (25%)	14° (25%)	
	Tire Type		Solid	Solid	Solid	
	Maximum Drive Height		Fully Elevated	Fully Elevated	Fully Elevated	

1 Not available on SV1930E model  
 2 Standard on SV2032E, SV2632E, SV2646E, and SV3246E models  
 3 Function speeds and gradeability assume there is one person on the platform and the battery is fully charged

4 Travel speed and gradeability are subject to surface conditions and sufficient traction  
 5 Weight information is approximate and does not take into account different option configurations or special designs

# LIFT SPECIFICATIONS

## MODEL NUMBERS

DIMENSIONS AND WEIGHT		SV2632E		SV2646E		SV3246E		
<b>A</b>	Overall Length	ft in (m)	7' 6.6" (2.3)		8' 2.4" (2.5)		8' 2.4" (2.5)	
<b>B</b>	Overall Length with Fold-down Guardrails Folded	ft in (m)	8' 2" (2.49)		8' 9.6" (2.69)		8' 9.6" (2.69)	
<b>C</b>	Overall Width	in (cm)	31.9" (81)		46.1" (1.17)		46.1" (1.17)	
<b>D</b>	Overall Height	ft in (m)	7' 7.4" (2.33)		7' 7.4" (2.33)		7' 7.4" (2.33)	
<b>E</b>	Overall Height with Fold-down Guardrails Folded	ft in (m)	6' 6.2" (1.99)		6' 6.2" (1.99)		6' 6.2" (1.99)	
	Vehicle Weight US/CA <sup>5</sup>	lb (kg)	4630 (2100)		5270 (2390) / 6106 (2770)		5270 (2390) / 6526 (2960)	
	Turning Radius (Inside)	deg	0 deg		0 deg		0 deg	
<b>F</b>	Turning Radius (Outside)	in (m)	88.5 (2.25)		101.5 (2.58)		101.5 (2.58)	
<b>G</b>	Ground Clearance (Center of Wheelbase)	in (cm)	5.1 (13)		5.12 in (13 cm)		5.1 (13)	
<b>H</b>	Ground Clearance (w/ Pothole Protectors Deployed)	in (cm)	0.787 (2)		0.787 (2)		0.787 (2)	
<b>I</b>	Wheelbase	in (m)	73.9 (1.88)		81.8 (2.08)		81.8 (2.08)	
	Ground Bearing Pressure	psi	90		87		87	
	Tire Size (Diameter x Width)	in (cm)	16x4.9 (40.6x12.5)		16X4.9 (40.6X12.5)		16X4.9 (40.6X12.5)	
<b>J</b>	Tread (Front and Rear)	in (cm)	26.9 (68.5)		41.1 (1.05)		41.1 (1.05)	
PLATFORM		SV2632E		SV2646E		SV3246E		
	Platform Capacity at Lift Height	lb at in (kg at m)	500 @ 306 (227 @ 7.77)		800 @ 236 (363 @ 6.0)		1000 @ 311 (454 @ 7.9)	
	Platform Extension Capacity	lb (kg)	250 (113)		250 (113)		250 (113)	
	Platform Working Height	ft (m)	32 (9.75)		32 (9.75)		38 (11.6)	
	Platform Height	Lowered	in (m)		47.8 (1.22)		47.8 (1.22)	
		Elevated	ft (m)		26 (7.92)		26 (7.92)	
<b>K</b>	Platform Inner Length	in (cm)	86.7 (220)		94.7 (241)		94.7 (241)	
<b>L</b>	Platform Extension Length	in (cm)	35.4 (90)		49.9 (127)		49.9 (127)	
<b>M</b>	Platform Inner Width	in (cm)	26.8 (68)		40.7 (103)		40.7 (103)	
<b>N</b>	Platform Railing Height	in (cm)	43.3 (111)		43.3 (111)		43.3 (111)	
	Scissor Link Stages	#	4		4		4	
PERFORMANCE		SV2632E		SV2646E		SV3246E		
	Platform Lift/Lower Time	sec	33/37		40/50		55/60	
	Max Travel Speed <sup>3,4</sup>	Lowered	mph (km/h)		2.8 (4.5)		2.5 (4.0)	
		Elevated	mph (km/h)		0.5 (0.8)		0.5 (0.8)	
	Voltage	V	24		24		24	
	Drive System		Brushless Dual AC Motors		Brushless Dual AC Motors		Brushless Dual AC Motors	
	Gradeability <sup>3,4</sup>	deg (%)	14° (25%)		14° (25%)		14° (25%)	
	Tire Type		Solid		Solid		Solid	
	Maximum Drive Height		Fully Elevated		Fully Elevated		Fully Elevated	

1 Not available on SV1930E model  
 2 Standard on SV2032E, SV2632E, SV2646E, and SV3246E models  
 3 Function speeds and gradeability assume there is one person on the platform and the battery is fully charged

4 Travel speed and gradeability are subject to surface conditions and sufficient traction  
 5 Weight information is approximate and does not take into account different option configurations or special designs

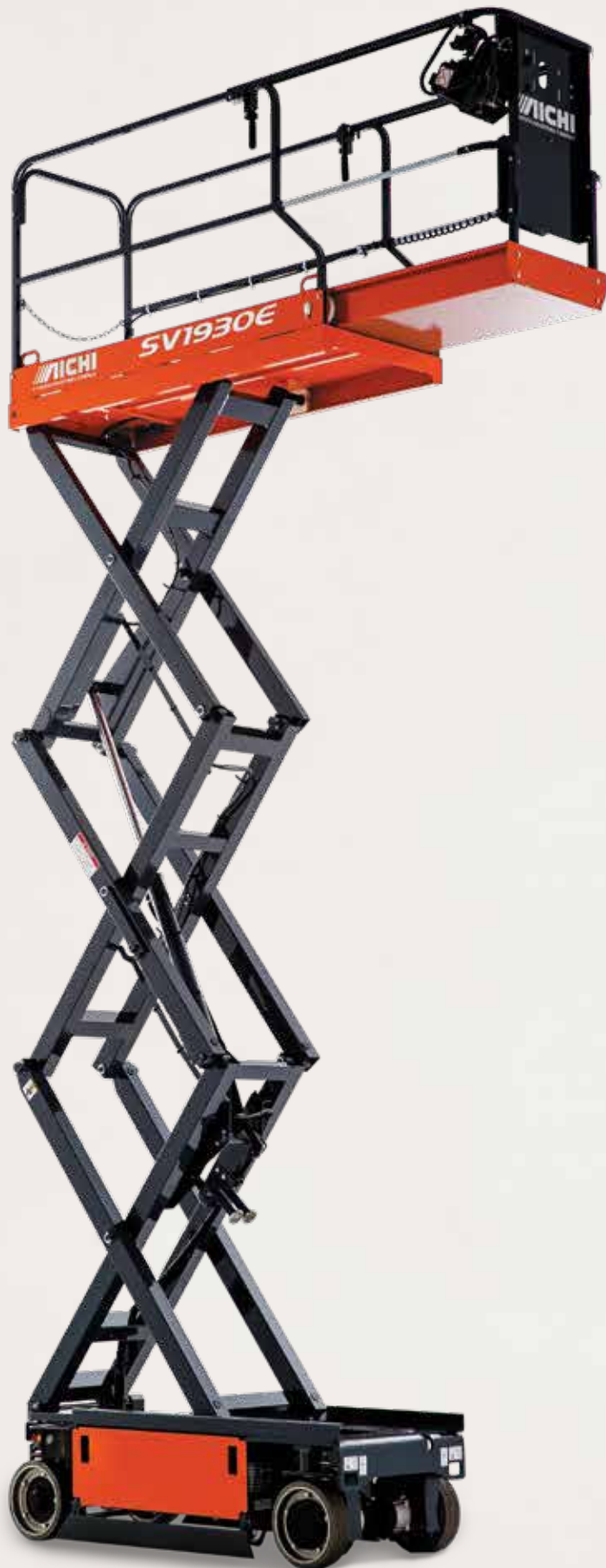

## AICHI E-SERIES SCISSOR LIFTS

- ▶ AICHI is a trusted worldwide aerial equipment manufacturer, renowned for its tradition of excellence and commitment to quality and efficiency.
- ▶ With 250,000 units sold worldwide since 1965 and a broad equipment range, AICHI has firmly established itself as a leading authority in aerial lifts. Over 50 years of business experience contributes to the company's success and expertise within the aerial work platform market.
- ▶ AICHI's industry-leading work is founded upon a tradition of excellence and a proven track record of innovation. Our implementation of thoughtful engineering considerations based on user feedback contribute to continued advancements like standard AC drive motors.
- ▶ AICHI's trusted brand joins Toyota's industry-leading network of dealers for product support to provide first-class customer service. Resources include factory-trained service technicians and flexible leasing and financing packages through Toyota Industries Commercial Finance.

For more information, including full specs, see your Toyota Dealer or visit [ToyotaForklift.com](https://www.toyotaforklift.com).

# AICHI

A TOYOTA INDUSTRIES COMPANY

Some product features described or depicted herein are optional. Please consult your dealer for specifications. Details of specifications and equipment are based on information available at time of printing and may change without notice.